

FURUNO

OPERATOR'S MANUAL

MARINE RADAR

Model **MODEL 1715**

IMPORTANT NOTICES

General

- This manual has been authored with simplified grammar, to meet the needs of international users.
- The operator of this equipment must read and follow the descriptions in this manual. Wrong operation or maintenance can cancel the warranty or cause injury.
- Do not copy any part of this manual without written permission from FURUNO.
- If this manual is lost or worn, contact your dealer about replacement.
- The contents of this manual and equipment specifications can change without notice.
- The example screens (or illustrations) shown in this manual can be different from the screens you see on your display. The screens you see depend on your system configuration and equipment settings.
- Save this manual for future reference.
- Any modification of the equipment (including software) by persons not authorized by FURUNO will cancel the warranty.
- The following concern acts as our importer in Europe, as defined in DECISION No 768/2008/EC.
 - Name: FURUNO EUROPE B.V.
 - Address: Ridderhaven 19B, 2984 BT Ridderkerk, The Netherlands
- All brand and product names are trademarks, registered trademarks or service marks of their respective holders.

How to discard this product

Discard this product according to local regulations for the disposal of industrial waste. For disposal in the USA, see the homepage of the Electronics Industries Alliance (<http://www.eiae.org/>) for the correct method of disposal.

How to discard a used battery

Some FURUNO products have a battery(ies). To see if your product has a battery, see the chapter on Maintenance. Follow the instructions below if a battery is used. Tape the + and - terminals of battery before disposal to prevent fire, heat generation caused by short circuit.

In the European Union

The crossed-out trash can symbol indicates that all types of batteries must not be discarded in standard trash, or at a trash site. Take the used batteries to a battery collection site according to your national legislation and the Batteries Directive 2006/66/EU.

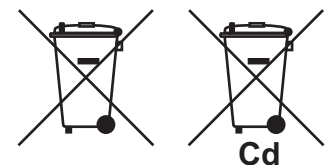

In the USA

The Mobius loop symbol (three chasing arrows) indicates that Ni-Cd and lead-acid rechargeable batteries must be recycled. Take the used batteries to a battery collection site according to local laws.

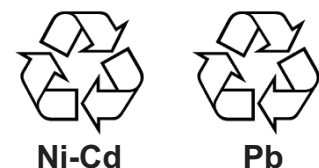

In the other countries

There are no international standards for the battery recycle symbol. The number of symbols can increase when the other countries make their own recycling symbols in the future.



SAFETY INSTRUCTIONS

Safety Instructions for the Operator

WARNING



ELECTRICAL SHOCK HAZARD
Do not open the equipment.

Only qualified personnel should work inside the equipment.



Wear a safety belt and hard hat when working on the antenna unit.

Serious injury or death can result if someone falls from the radar antenna mast.



The radar antenna emits electromagnetic radio frequency (RF) energy which can be harmful, particularly to your eyes. Never look directly into the antenna aperture from a close distance while the radar is in operation or expose yourself to the transmitting antenna at a close distance.

Distances at which RF radiation levels of 100 and 10 W/m² exist are given in the table below.

100 W/m ²	10 W/m ²
Nil	0.7 m

Do not disassemble or modify the equipment.





Fire, electrical shock or serious injury can result.

Turn off the power immediately if water leaks into the equipment or the equipment is emitting smoke or fire.

Continued use of the equipment can cause fire or electrical shock.

WARNING LABEL

A warning label is attached to the equipment. Do not remove the label. If the label is missing or damaged, contact a FURUNO agent or dealer about replacement.

 WARNING 
To avoid electrical shock, do not remove cover. No user-serviceable parts inside.
 

Name: Warning Label (1)
Type: 86-003-1011-1
Code No.: 100-236-231

Safety Instructions for the Installer

WARNING



ELECTRICAL SHOCK HAZARD
Do not open the equipment unless totally familiar with electrical circuits and service manual.

Only qualified personnel should work inside the equipment.



Wear a safety belt and hard hat when working on the antenna unit.

Serious injury or death can result if someone falls from the radar antenna mast.

Construct a suitable service platform from which to install the antenna unit.

Serious injury or death can result if someone falls from the radar antenna mast.

Be sure that the power supply is compatible with the voltage rating of the equipment.

Connection of an incorrect power supply can cause fire or damage the equipment.

Use only the specified power cable.

Fire or damage to the equipment can result if a different cable is used.

CAUTION

Observe the following compass safe distances to prevent interference to a magnetic compass:

	Standard compass	Steering compass
Display unit	0.60 m	0.40 m
Antenna unit	1.25 m	0.85 m

Use the proper fuse.

Use of a wrong fuse can damage the equipment and void the warranty.

TABLE OF CONTENTS

FOREWORD	v	2. MAINTENANCE, TROUBLESHOOTING	18
SYSTEM CONFIGURATION	vi	2.1 Maintenance	18
EQUIPMENT LISTS	vii	2.2 Replacing the Fuse	19
1. OPERATION	1	2.3 Troubleshooting	19
1.1 Controls	1	2.4 Diagnostics	20
1.2 Indications	2	2.5 Test Pattern	21
1.3 Turning Power On/Off	3	2.6 Clearing the Memory	21
1.4 Transmitting, Standby	3	2.7 Replacing the Magnetron	21
1.5 Adjusting Display Contrast, Brilliance	4	2.8 Replacing the Synchro Belt	21
1.6 Choosing the Range	4	3. INSTALLATION	22
1.7 Receiver Sensitivity	4	3.1 Antenna Unit Installation	22
1.8 Suppressing Sea Clutter	5	3.2 Display Unit Installation	25
1.9 Suppressing Rain Clutter	6	3.3 Wiring	26
1.10 Measuring the Range	6	3.4 Adjustments	27
1.11 Measuring the Bearing	7	3.5 Magnetron Heater Voltage	30
1.12 Shifting the Display	7	MENU TREE	31
1.13 Zoom	8	SPECIFICATIONS	SP-1
1.14 User Menu Overview	8	OUTLINE DRAWINGS	D-1
1.15 Heading Line	9	INTERCONNECTION DIAGRAM	S-1
1.16 Interference Rejector	9		
1.17 Noise Rejector	10		
1.18 Echo Trail, Trail Brilliance	10		
1.19 Echo Stretch	10		
1.20 Guard Alarm	11		
1.21 Watchman	12		
1.22 Suppressing Heavy Rain Clutter	12		
1.23 Panel Backlighting	12		
1.24 Hue	13		
1.25 Resetting Distance Run	13		
1.26 PROG Key	13		
1.27 Outputting Target Position to a Plotter .	13		
1.28 Turning Navigation Data On/Off	14		
1.29 Setting up Nav Data Displays	14		
1.30 System Menu	16		

FOREWORD

A Word to the Owner of the MODEL 1715

Congratulations on your choice of the FURUNO MODEL 1715 Marine Radar.

Since 1948, FURUNO Electric Company has enjoyed an enviable reputation for innovative and dependable marine electronics equipment. This dedication to excellence is furthered by our extensive global network of agents and dealers.

Your radar is designed and constructed to meet the rigorous demands of the marine environment. However, no machine can perform its intended function unless installed, operated and maintained properly. Please carefully read and follow the recommended procedures for installation, operation, and maintenance.

We would appreciate hearing from you, the end-user, about whether we are achieving our purposes.

Thank you for considering and purchasing FURUNO equipment.

Program No.

0359199-02.**

** denotes minor modifications.

Features

Your radar has a large variety of functions, all contained in a rugged plastic case. All controls respond immediately to the operator's command and each time a key is pressed the corresponding change can be seen on the screen.

The main features of the MODEL 1715 are

- Daylight viewing radar specially designed for small craft and sailing yachts.
- Traditional FURUNO reliability and quality in a compact, light-weight and low-cost radar.
- Compact and light-weight radome antenna with precision 45 cm center-fed radiator.
- High definition 7-inch monochrome LCD display.
- Automatic control of sensitivity (gain), tuning and A/C SEA for simplified operation.
- Targets can be displayed in grey tones on a white background or vice versa, for optimal viewing under any lighting conditions.
- On-screen alphanumeric readout of all operational information.
- User programmable nav data displays.
- [PROG] key acts as a menu shortcut key.
- [TLL] key outputs chosen target's L/L position to a plotter.
- Standard features include Display Shift, EBL, Echo Stretch, Echo Trail, Guard Alarm, Interference Rejector, VRM, Zoom.
- Guard zone watches for targets entering (or exiting) a guard zone.

SYSTEM CONFIGURATION

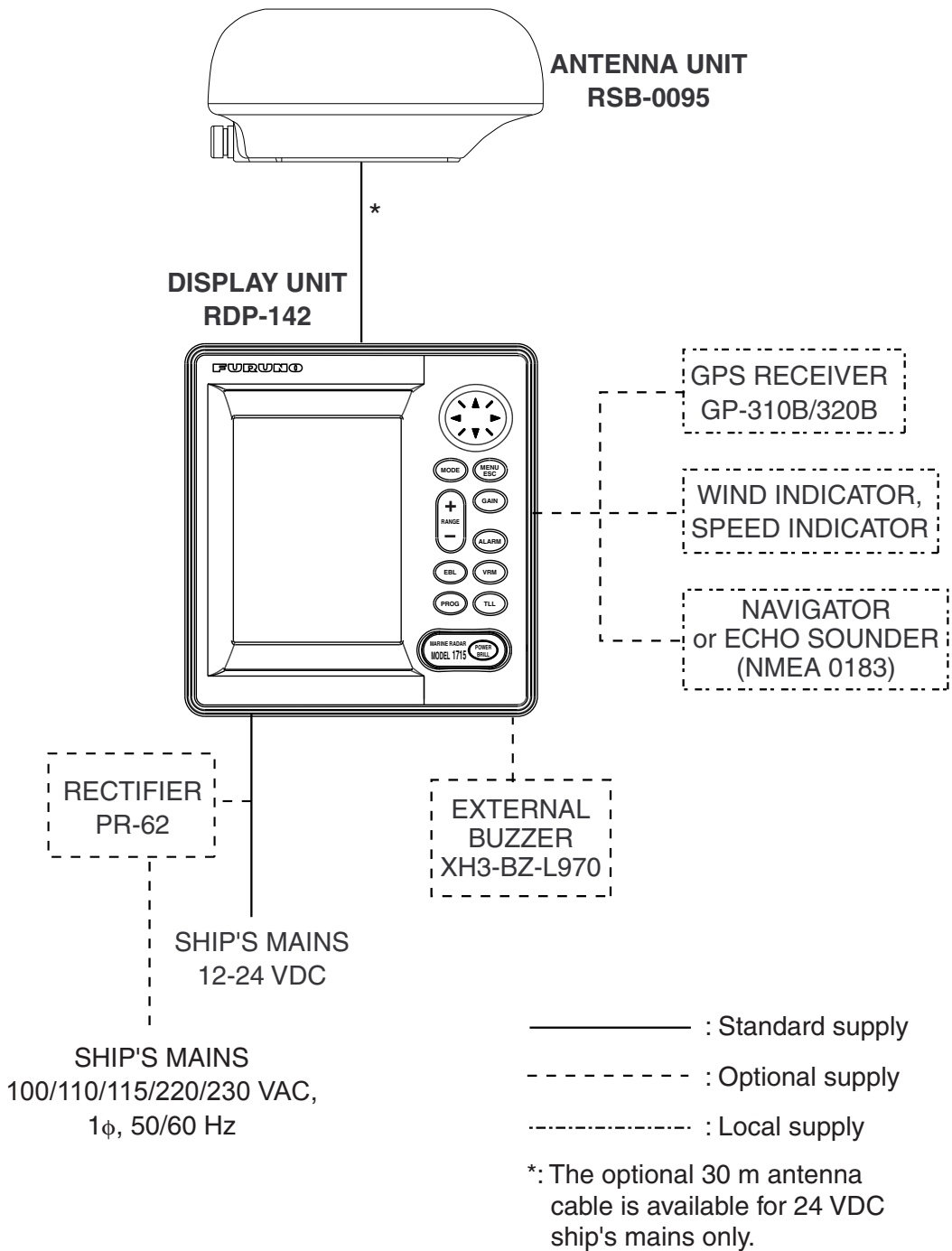

EQUIPMENT LISTS

Standard supply

Name	Type	Code No.	Qty	Remarks
Antenna Unit	RSB-0095-076	—	1	
Display Unit	RDP-142	—	1	
Installation Materials	CP03-25301	008-442-280	1 set	Antenna unit inst. materials
	CP03-24910	000-080-231	1 set	Antenna cable (10 m) Type: MJ-A10SPF0003-100 Code No.: 000-129-609
	CP03-24920	000-080-232		Antenna cable (15 m) Type: MJ-A10SPF0009-150 Code No.: 000-144-564
	CP03-24930	000-080-233		Antenna cable (20 m) Type: MJ-A10SPF0009-200 Code No.: 000-144-565
	CP03-25101	008-441-250	1 set	For display unit
Spare Parts	SP03-14301	008-442-270	1 set	Fuse (2 pcs.) Type: FGBO-A 125V 5A, Code No: 000-155-853-10
Template (1)	C32-00302	000-148-148	1	For flush mounting
Template (2)	C32-00303	000-148-149	1	For bulkhead mounting

Optional supply

Name	Type	Code No.	Qty	Remarks
Cable Assy.	XH3-BZ-L970	000-146-422	1	With connector, 0.9 m
Cable Assy.	MJ-A7SPF0007-050	000-144-418	1	Connector at one end, 5 m, for NMEA
Cable Assy.	MJ-A15A7F0004-005	000-145-690	1	For NMEA, 0.5 m, With connector at both ends (7P-7P/6P)
Cable Assy.	MJ-A15A7F0005-020	000-145-691	1	7P-7P, for NMEA, 2 m
Cable Assy.	MJ-A10SPF0003-300	000-130-034	1	30 m antenna cable, for 24 VDC only
Radome Mtg. Assy.	OP03-93	008-445-080	1	For mounting antenna on mast
Rectifier	PR-62	000-013-484	1	For 100 VAC
	PR-62	000-013-485		For 110-115 VAC
	PR-62	000-013-486		For 220 VAC
	PR-62	000-013-487		For 230 VAC
Antenna Unit	RSB-0095-076	—	1	

Antenna installation materials

Name	Type	Code No.	Qty	Remarks
EMI Core	RFC-H13	000-146-570	1	
Slotted Head Hex Bolt	M10x25 SUS304	000-862-308	4	
Pan Head Screw B	M4x15 C2700W MBNI2	000-881-448	1	
EMI Core Fixing Band	03-160-1026	100-302-450	1	

Display unit installation materials

Name	Type	Code No.	Qty	Remarks
Tapping Screw	5x20 SUS304	000-802-081	4	
Pan Head Screw B	M4x20 SUS304	000-804-742	4	
Cable Assy. MJ	MJ-A15A3F0019-035-5A	000-147-564	1	

This page is intentionally left blank.

1. OPERATION

1.1 Controls

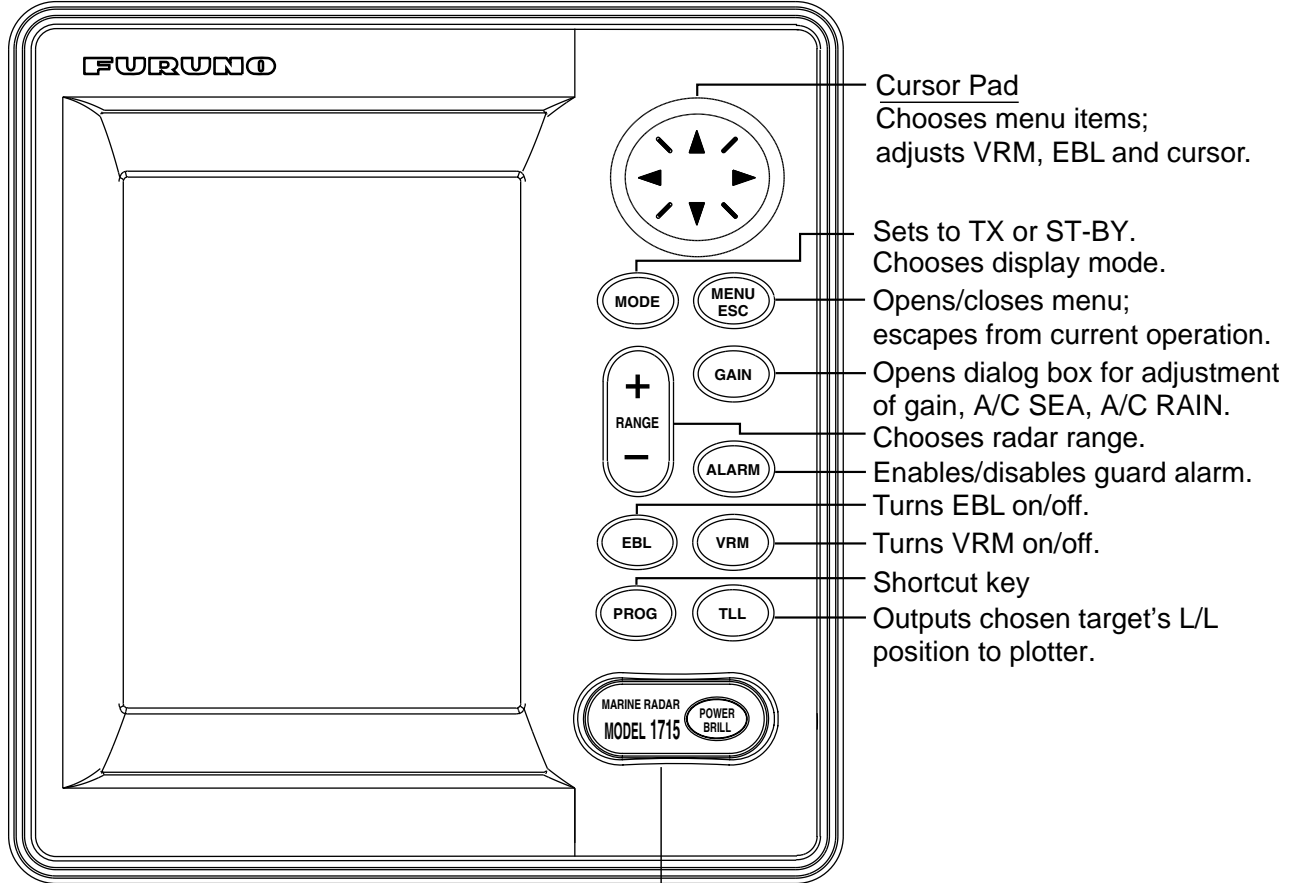

How to remove the hard cover

Place your thumbs at the center of the cover, and then lift the cover while pressing it with your thumbs.

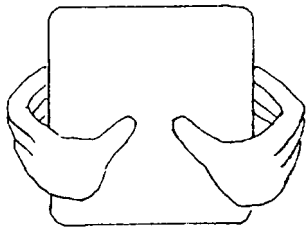

Short press: Turns power on.

Long press: Turns power off.

Momentary press: Opens dialog box for adjustment of display contrast, brilliance and mode (TX, ST-BY) selection.

Display unit

1.2 Indications

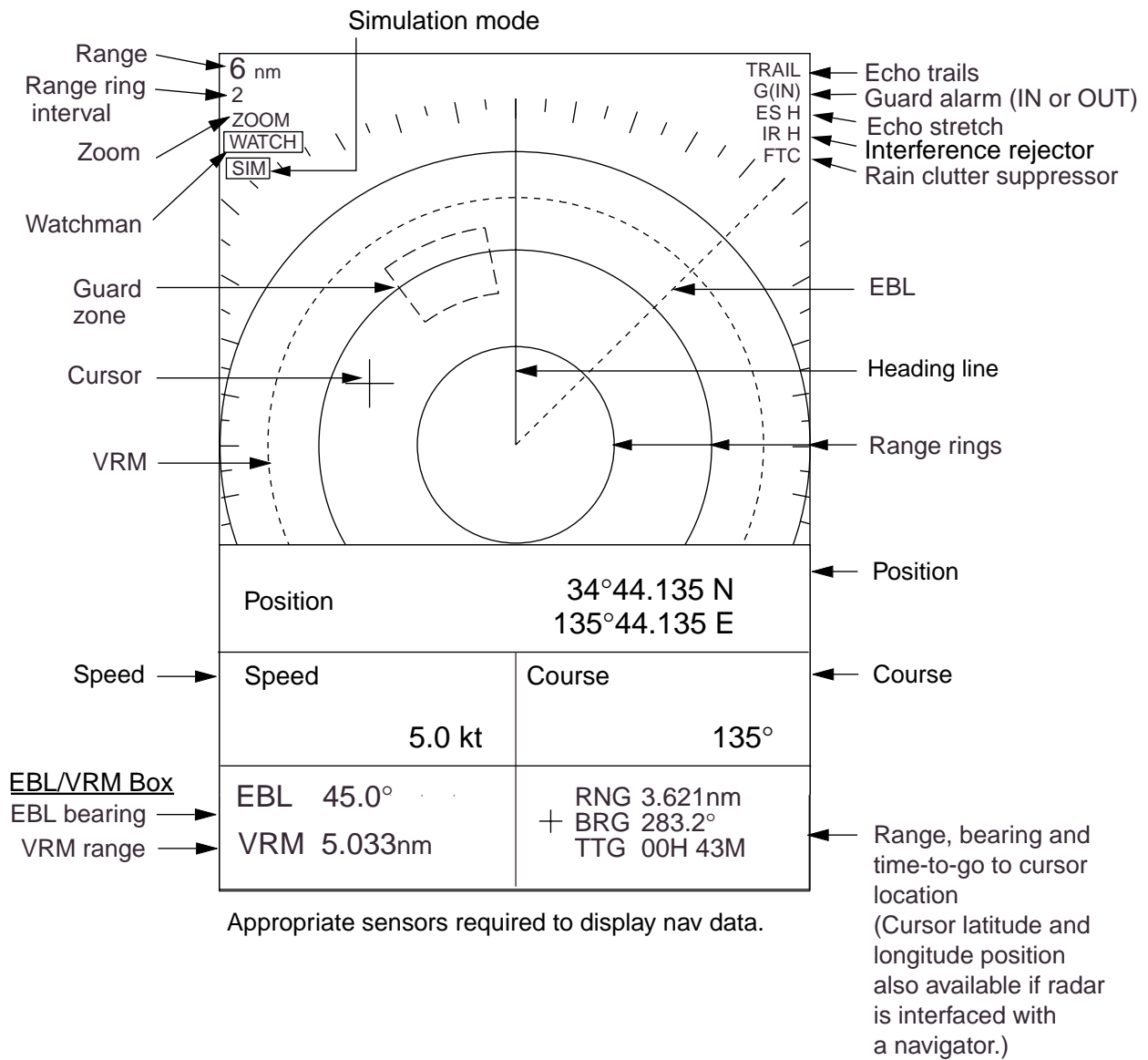

Indications

About the LCD

The high quality LCD displays better than 99.99% of its picture elements. The remaining elements may drop out or light, however this is not an indication of malfunction; it is a characteristic of the LCD.

1. OPERATION

1.3 Turning Power On/Off

Press the [POWER/BRILL] key to turn on the power. The unit beeps, the startup screen appears, and then the equipment checks the ROM and RAM for proper operation and displays program number. The ROM and RAM check shows OK or NG (No Good). If NG appears, try to press any key except the [POWER/BRILL] key to continue. If the equipment does not work properly, contact your dealer for advice.

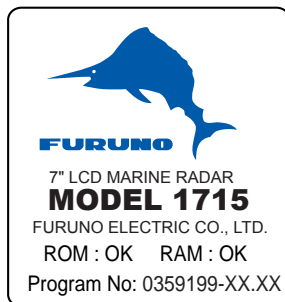

XX.XX = Program version no.

Startup screen

After the completion of the startup test, a timer displays the time remaining for warm up of the magnetron (the device which transmits radar pulses), counting down from 1:00 to 0:00.

To turn off the power, press and hold down the [POWER/BRILL] key (about three seconds) until the screen goes blank.

Provided that the radar was once in use with the transmitter tube (magnetron) still warm, you can turn the radar into TRANSMIT condition without 1-minute of warm-up. If the [POWER/BRILL] key was accidentally turned off and you want to restart the radar promptly, turn on the [POWER/BRILL] key not later than 15 seconds after power-off.

Note 1: In a cold environment the screen appears "foggy" when the power is turned on but is soon restored to normal condition.

Note 2: Windows other than menu windows are erased when there is no operation within about 10 seconds.

1.4 Transmitting, Standby

After the power is turned on and the magnetron has warmed up, "ST-BY" (Stand-by) appears, indicating the radar is ready to transmit radar pulses.

To toggle between transmit and stand-by, do as below. Note that you may also do this with "TX/ST-BY" on the User menu.

1. With the power turned on, press the [POWER/BRILL] key momentarily to show the brilliance/contrast adjustment window.

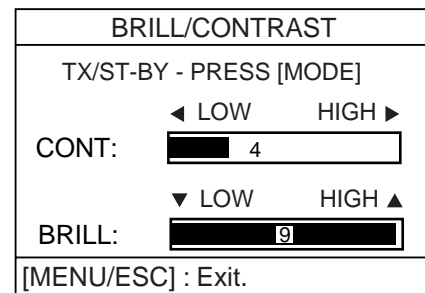

Brilliance/contrast adjustment window

2. Press the [MODE] key to go to stand-by and transmit status alternately.

Note: If you attempt to transmit before "ST-BY" appears, the beeps sound and the radar does not transmit pulses. Wait until "ST-BY" appears.

3. Press the [MENU/ESC] key to close the window.

When radar pulses are transmitted the radar receiver is automatically tuned. Echoes appear in four levels of digitized video according to echo strength.

1.5 Adjusting Display Contrast, Brilliance

1. With the power turned on, press the [POWER/BRILL] key momentarily to show the brilliance/contrast adjustment window.

BRILL/CONTRAST	
TX/ST-BY - PRESS [MODE]	
CONT:	◀ LOW HIGH ▶ ████████ 4
BRILL:	▼ LOW HIGH ▲ ████████ 9
[MENU/ESC] : Exit.	

Brilliance/contrast adjustment window

2. Press ◀ or ▶ to adjust contrast.
3. Press ▲ or ▼ to adjust brilliance.
4. Press the [MENU/ESC] key to escape.

Note: The radar starts up with the last-used brilliance level after the startup screen appears. Therefore, adjust the brilliance if it is too low at startup.

1.6 Choosing the Range

The range selected automatically determines the range ring interval, the number of range rings and pulse repetition rate.

Press the [RANGE+] or [RANGE-] key to choose the range. The range and range ring interval appear at the top left corner on the screen.

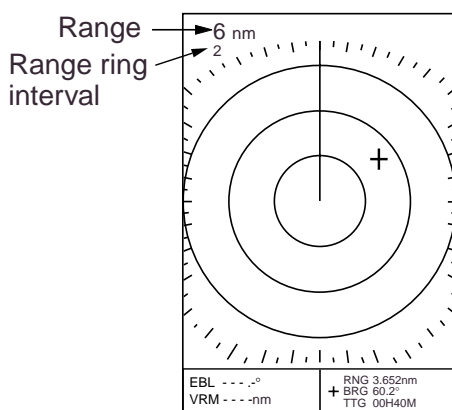

Location of range and range ring interval indications

1.7 Receiver Sensitivity

The gain control adjusts the sensitivity of the receiver. It works in precisely the same manner as the volume control of a broadcast receiver, amplifying the signals received. The proper setting is such that the background noise is just visible on the screen. If you set up for too little sensitivity, weak echoes may be missed. On the other hand excessive sensitivity yields too much background noise; strong targets may be missed because of the poor contrast between desired echoes and the background noise on the display.

To adjust receiver sensitivity, adjust the gain control so background noise is just visible on the screen.

1. Press the [GAIN] key consecutively until the display shown below appears.

GAIN	
AUTO	: MODERATE
MANU	████████ 20
[GAIN] : A/C SEA MENU	
[MENU/ESC] : Exit.	

Gain adjustment window

2. Press ▲ or ▼ to choose AUTO or MANU as appropriate.

Automatic gain adjustment

- 1) Press ▶ to open the automatic gain options window.

ROUGH
MODERATE
CALM

Automatic gain options

- 2) Press ▲ or ▼ to choose ROUGH, MODERATE or CALM depending on sea conditions.
- 3) Press ◀ to close the window.

1. OPERATION

Manual gain adjustment

While observing the screen and the gain tuning bar, press ◀ or ▶ to adjust the gain. The setting range is 0-100.

3. Press the [MENU/ESC] key to finish.

1.8 Suppressing Sea Clutter

Echoes from waves cover the central part of the display with random signals known as sea clutter. The higher the waves, and the higher the scanner above the water, the further the clutter will extend. When sea clutter masks the picture, suppress it by the A/C SEA control.

Automatic adjustment by the A/C SEA control

Sea clutter, as well as rain clutter, can be automatically adjusted with the automatic A/C SEA function.

Manual adjustment of A/C SEA

The A/C SEA control reduces the amplification of echoes at short ranges (where clutter is the greatest) and progressively increases amplification as the range increases, so amplification will be normal at those ranges where there is no sea clutter.

The proper setting of the A/C SEA should be such that the clutter is broken up into small dots, and small targets become distinguishable.

If the setting is set too low, targets will be hidden in the clutter, while if the setting is too high, both sea clutter and targets will disappear from the display. In most cases adjust the control until clutter has disappeared to leeward, but a little is still visible windward.

Note: The auto A/C SEA function can erase weak target echoes. Adjust the control carefully watching the display.

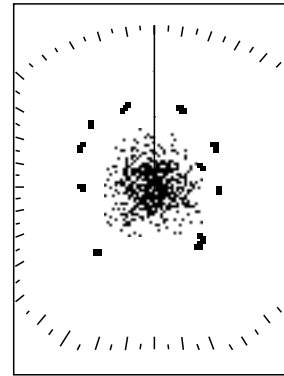

Sea clutter at screen center

1. Press the [GAIN] key consecutively until the display shown below appears.

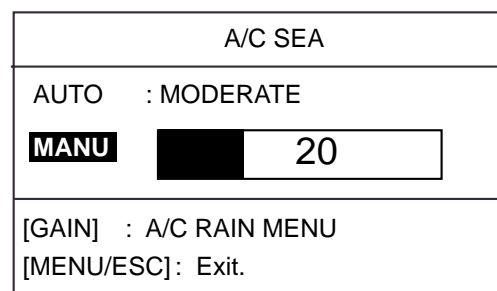

A/C SEA adjustment window

2. Press ▲ or ▼ to choose AUTO or MANU as appropriate.

Automatic A/C SEA adjustment

- 1) Press ▶ to open the automatic A/C SEA options window.

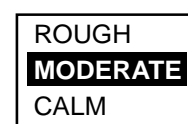

A/C SEA options

- 2) Press ▲ or ▼ to choose ROUGH, MODERATE or CALM depending on sea conditions.
- 3) Press ◀ to close the window.

Manual A/C SEA adjustment

While observing the screen and the A/C SEA tuning bar, press ◀ or ▶ to adjust the A/C SEA. The setting range is 0-100.

- Press the [MENU/ESC] key to finish.

1.9 Suppressing Rain Clutter

The vertical beamwidth of the antenna is designed to see surface targets even when the ship is rolling. However, by this design the antenna will also pick up rain clutter (rain, snow, or hail) in the same manner as normal targets. The illustration below shows the appearance of rain clutter on the display.

The A/C RAIN control adjusts the receiver sensitivity as the A/C SEA control does but rather in a longer time period. The higher the setting the greater the anti-clutter effect.

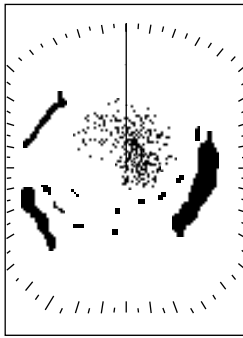

Rain clutter at screen center

- Press the [GAIN] key consecutively until the display shown below appears.

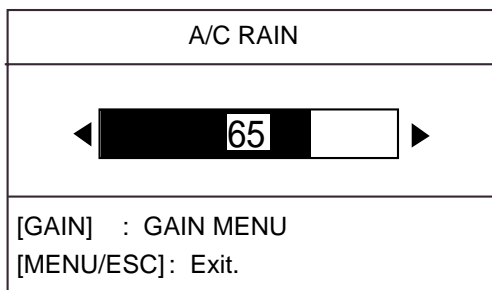

A/C RAIN adjustment window

- While observing the screen and the A/C RAIN tuning bar, press ◀ or ▶ to adjust the A/C RAIN. The setting range is 0-100.
- Press the [MENU/ESC] key to finish.

1.10 Measuring the Range

The bearing to a target can be measured by the range rings, by the cursor and by the VRM (Variable Range Marker).

Measuring range by the range rings

Count the number of rings between the center of the display and the target. Check the range ring interval and judge the distance of the echo from the inner edge of the nearest ring.

Measuring range by the cursor

Operate the cursor pad to place the cursor on the inside edge of the target. Read the range to the cursor at the bottom right corner of the display.

Measuring range by the VRM

- Press the [VRM] key to display the VRM. The message "Place VRM by cursor" appears and "VRM" in the EBL/VRM box is displayed in reverse video. The message is automatically erased after 10 seconds, or you may erase it sooner by pressing any key.
- Operate the cursor pad to place the VRM on the inside edge of the target.
- Check the VRM readout at the bottom left corner on the screen to find the range to the target.

To anchor the VRM, press the [VRM] key. (It is automatically anchored if there is no key operation for about 10 seconds.) To erase the VRM, press the [MENU/ESC] key.

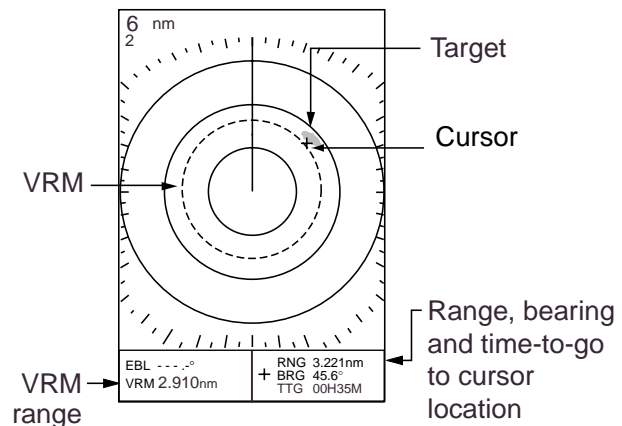

How to measure the range

1. OPERATION

1.11 Measuring the Bearing

The bearing to a target can be measured with the cursor and the EBL (Electronic Bearing Line).

Measuring bearing with the cursor

Operate the cursor pad to place the cursor on the center of the target. Read the bearing to the target at the bottom right corner.

Measuring bearing with the EBL

1. Press the [EBL] key to show the EBL. The message "Place EBL by cursor" appears and "EBL" in the EBL/VRM box is displayed in reverse video. The message is automatically erased after 10 seconds, or you may erase it sooner by pressing any key.
2. Operate the cursor pad to bisect the target with the EBL.
3. Check the EBL readout at the bottom left corner on the screen to find the bearing to the target.

To anchor the EBL, press the [EBL] key. (It is automatically anchored if there is no key operation for about 10 seconds.) To erase the EBL, press the [MENU/ESC] key.

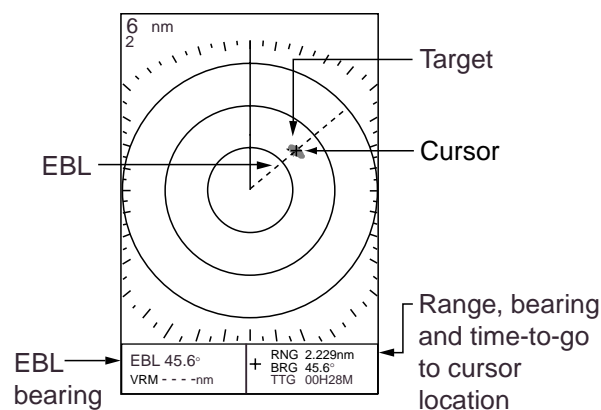

How to measure bearing by the EBL and cursor

1.12 Shifting the Display

Own ship position, or sweep origin, can be displaced manually or automatically to expand the view field without switching to a longer range. The default shift method is manual and the maximum shift is 60% of range.

If shift is activated when nav data is displayed, the nav data is automatically erased.

1. Use the cursor pad to place the cursor where you want to shift own ship position.
2. Press the [MODE] key to show the Display Mode menu.

DISPLAY MODE	
▲ SHIFT (MANUAL)*	
NORMAL	
▼ ZOOM	
NAV DISP	◀ OFF ON ▶
[MENU/ESC] : Exit.	

Display mode menu

*: If SHIFT (AUTO) is shown, open the System menu and set SHIFT MODE to MANUAL. For further details, see SHIFT MODE on page 17.

3. Press ▲ to choose SHIFT (MANUAL).
4. Press the [MENU/ESC] key to close the menu.

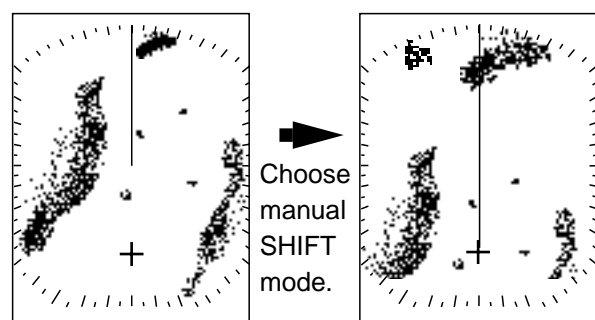

Select where to shift with the cursor.

Shifted display

How the manual shift works

To cancel the shifted display, open the Display Mode menu, set SHIFT to NORMAL and then press the [MENU/ESC] key.

1.13 Zoom

The zoom feature allows you to double the size of a selected area.

If zoom is activated when nav data is displayed, the nav data is automatically erased.

1. Use the cursor pad to place the cursor where you want to zoom.
2. Press the [MODE] key to show the display mode menu.

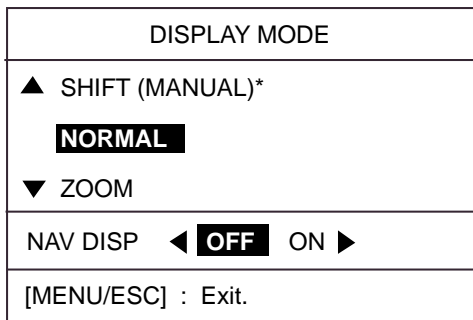

Display mode menu

3. Press ▼ to choose ZOOM.
4. Press the [MENU/ESC] key to close the menu. The area selected with the cursor appears in the zoom window and “ZOOM” appears at the top left corner.

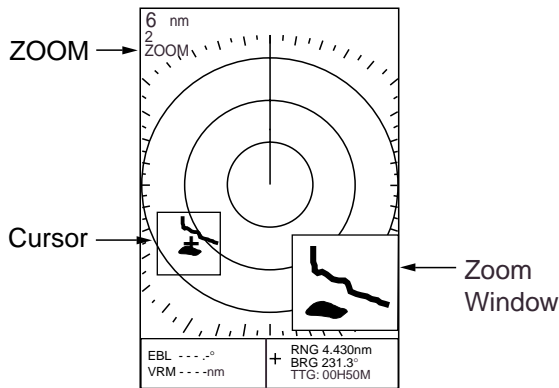

Zoom display

To cancel the zoom display, open the Display Mode menu, choose NORMAL and then press the [MENU/ESC] key. To choose new zoom location, restore to the NORMAL mode and then repeat the zoom procedure.

1.14 User Menu Overview

The User menu, consisting of three pages of menus, contains 10 items which the user may set according to conditions or preference.

1. Press the [MENU/ESC] key to open the User menu.

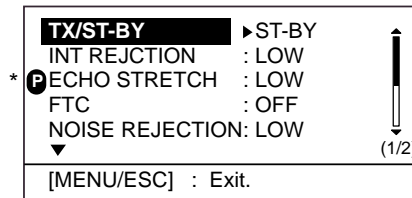

* = "P" shows current function of PROG key

User menu, page 1

2. Use ▲ or ▼ to scroll the menu to display desired item in reverse video.

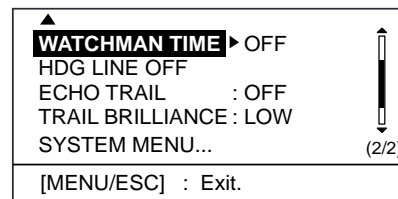

User menu, page 2

3. Press ▶ to show the options window for the item selected. For example, the illustration below shows the interference rejector options window.

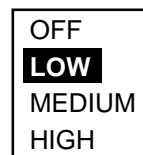

Interference rejector options

4. Press ▲ or ▼ to choose option desired.
5. Press ◀ to continue menu operation, or press the [MENU/ESC] key to register your selection and close the User menu.

User menu description

Item	Description
TX/ST-BY	Sets radar in transmit or stand-by status. (Same functions as the [MODE] key.)
INT REJECTION	Rejects radar interference.
ECHO STRETCH	Stretches echoes in range direction or range and bearing direction.
FTC	Suppresses long-range rain clutter.
NOISE REJECTION	Rejects noise.
WATCHMAN TIME	Periodically checks for targets in guard zone.
HDG LINE OFF	Temporarily turns the heading line off.
ECHO TRAIL	Shows echo movement in afterglow.
TRAIL BRILLIANCE	Adjusts echo trail brilliance.
SYSTEM MENU	Opens the system menu. For description see paragraph 1.30.

1.15 Heading Line

The heading line indicates the ship's heading and it is the solid line which appears at zero degrees on the bearing scale.

To temporarily erase the heading line to look at targets existing dead ahead of own ship, do the following:

1. Press the [MENU/ESC] key to open the User menu.
2. Press ▲ or ▼ to choose HDG LINE OFF from page 2.
3. Press ► to turn the heading line off. The line stays off while ► is pressed.
4. Press the [MENU/ESC] key to close the menu.

1.16 Interference Rejector

Mutual radar interference may occur in the vicinity of another shipborne radar operating in the same frequency band (9 GHz). It is seen on the screen as a number of bright spikes either in irregular patterns or in the form of usually curved spoke-like dotted lines extending from the center to the edge of the picture. This type of interference can be reduced by activating the interference rejector circuit. "IR" and the rejection level indicator "L," "M" or "H" appear at the top right corner when the interference rejector circuit is on.

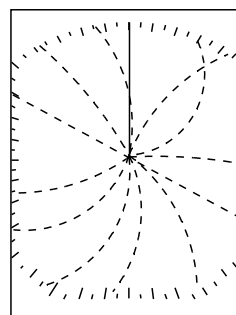

Appearance of interference

Turn off the interference rejector when no interference exists, to avoid missing small targets.

1. Press the [MENU/ESC] key to open the User menu.
2. Press ▲ or ▼ to choose INT REJECTION from page 1.
3. Press ► to open the options window.
4. Press ▲ or ▼ to choose OFF, LOW, MEDIUM or HIGH as appropriate.
5. Press the [MENU/ESC] key to finish.

1.17 Noise Rejector

The noise rejector suppresses white noise, which appears on the screen as many dots scattered randomly over the display.

1. Press the [MENU/ESC] key to open the User menu.
2. Press ▲ or ▼ to choose NOISE REJECTION from page 1.
3. Press ► to open the options window.
4. Press ▲ or ▼ to choose OFF, LOW or HIGH as appropriate.
5. Press the [MENU/ESC] key to close the menu.

1.18 Echo Trail, Trail Brilliance

Echo trails are the afterglow of target echoes that represent their movements relative to own ship. They are useful for monitoring target movement.

Trails are painted for the time period chosen. When the time period has elapsed, trails are erased and restarted. Trails are also erased and restarted whenever the range is changed or zoom or shift is activated.

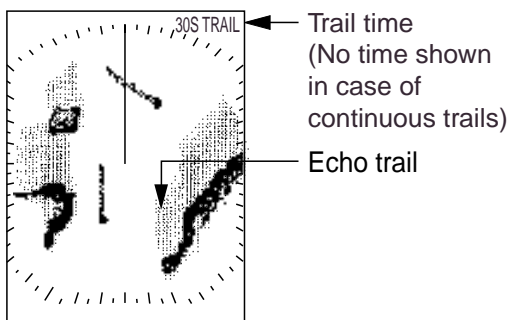

Echo trails

1. Press the [MENU/ESC] key to open the User menu.
2. Press ▲ or ▼ to choose ECHO TRAIL from page 2.
3. Press ► to open the options window.

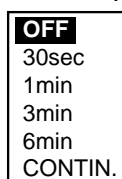

Echo trail options

4. Press ▲ or ▼ to choose appropriate time, or OFF to cancel echo trails. "CONTIN." paints trails continuously.
5. Press ◀ to close the options window.
6. Press ▼ to choose TRAIL BRILLIANCE.
7. Press ► to open the options window.
8. Press ▲ or ▼ to choose LOW or HIGH as appropriate.
9. Press the [MENU/ESC] key to close the menu.

"TRAIL" and trail time (no time shown in case of "CONTIN.") are shown at the upper right-hand corner on the screen.

1.19 Echo Stretch

On long ranges target echoes tend to shrink, making them difficult to see. To enhance target video on long ranges, use the echo stretch feature.

1. Press the [MENU/ESC] key to open the User menu.
2. Press ▲ or ▼ to choose ECHO STRETCH from page 1.
3. Press ► to open the options window.
4. Press ▲ or ▼ to choose OFF, LOW or HIGH as appropriate. LOW stretches echoes in the bearing direction; HIGH stretches echoes in the range and bearing directions. "ES L" or "ES H" appears at the top right-hand corner when echo stretch is turned on.
5. Press the [MENU/ESC] key to close the menu.

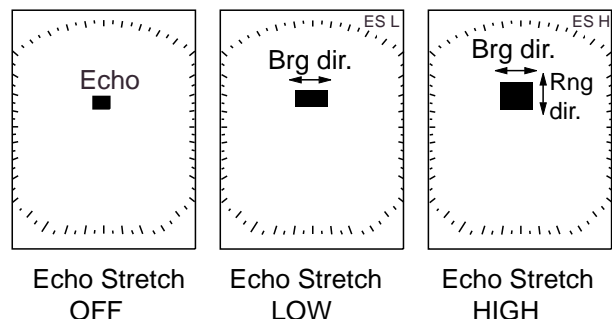

How echo stretch works

1. OPERATION

1.20 Guard Alarm

The guard alarm allows the operator to set the desired range and bearing for a guard zone. When ships, islands, landmasses, etc. violate the guard zone, audio and visual alarms are released to call your attention. The alarms will be released for targets entering or exiting the zone depending on the presence or absence of targets in the zone when the alarm is set.

NOTICE
<p>* The alarm should not be relied upon as the sole means for detecting possible collision situations.</p> <p>* A/C SEA, A/C RAIN, FTC and GAIN controls should be properly adjusted to be sure the weak echoes will not be missed by the alarm.</p>

Setting a guard zone

1. Operate the cursor pad to place the cursor at the top left corner for the zone and then press the [ALARM] key.
2. Operate the cursor pad to place the cursor at the bottom right corner for the zone and then press the [ALARM] key.

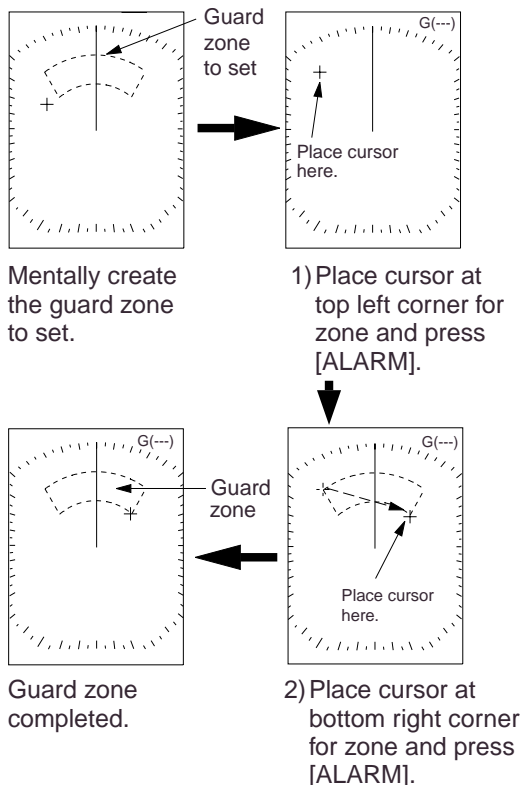

How to set a guard zone

How guard zone type is determined

After the guard zone has been set, the radar checks for targets inside the guard zone, which takes about 8 to 12 seconds. When the check is completed, "G(IN)" or "G(OUT)" replaces G(---) at the top right corner.

G(IN): When no target exists in the zone, "G(IN)" appears. The audio alarm sounds against targets which enter the guard zone.

G(OUT): If there are targets in the guard zone, "G(OUT)" appears. The audio alarm sounds against all targets which exit from the guard zone.

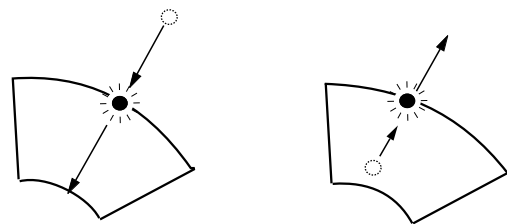

(a) Inward target alarm (b) Outward target alarm

Inward and outward alarms

Note: The guard zone disappears when it is not within the range in use. When this occurs "UP RNG" replaces G(IN) or G(OUT). Change the range to redisplay the guard zone.

Silencing the audio alarm

When a target violates the guard zone, the target flashes and the audio alarm sounds. You can silence the audio alarm with the [ALARM] key. The target continues flashing until the reason for the alarm ends or the guard zone is canceled.

Canceling the guard zone and guard alarm

Press and hold down the [ALARM] key until the guard zone is erased.

1.21 Watchman

How watchman works

Watchman transmits the radar for one minute to check if a target has entered or exited the guard zone from the previous transmission. If no change is found, the radar goes into stand-by for the number of minutes set for the watchman feature. If change is found, the audio alarm sounds, watchman is canceled and the radar transmits. This feature is useful for extending the life of the magnetron.

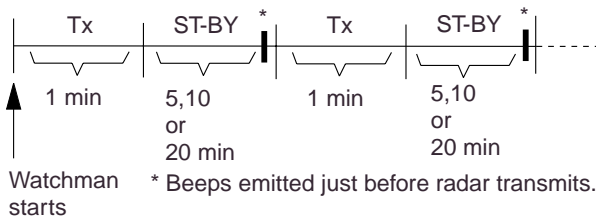

How watchman works

Setting watchman stand-by interval

The watchman stand-by interval, that is, the number of minutes the radar is in standby, can be set to 5, 10 or 20 minutes as follows:

1. Set a 360° guard zone referring to paragraph 1.20.
2. Press the [MENU/ESC] key to open the User menu.
3. Press ▲ or ▼ to choose WATCHMAN TIME from page 2.
4. Press ► to open the options window.

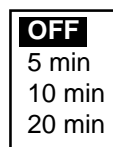

Watchman time options

5. Press ▲ or ▼ to choose appropriate time out, that is, the amount of time the radar waits in standby, among 5, 10 and 20 minutes.
6. Press the [MENU/ESC] key to close the menu.

Note 1: To turn off the watchman feature, choose OFF at step 5.

Note 2: You cannot put the radar in stand-by when the radar is transmitting for the watchman feature.

1.22 Suppressing Heavy Rain Clutter

In adverse weather, clouds, rain or snow produce spray-like spurious echoes which impair target detection over all ranges. These echoes can be suppressed by turning on the FTC (Fast Time Constant). FTC works by splitting up these unwanted echoes into a speckled pattern, making recognition of solid targets easier.

1. Press the [MENU/ESC] key.
2. Press ▲ or ▼ to choose FTC from page 1.
3. Press ► to open the options window.
4. Press ▲ or ▼ to choose OFF or ON as appropriate.
5. Press the [MENU/ESC] key to close the menu.

“FTC” appears at the top right corner when the FTC is active.

1.23 Panel Backlighting

You may adjust panel backlighting as follows:

1. Press the [MENU/ESC] key to open the User menu.
2. Press ▼ to choose SYSTEM MENU.
3. Press ▲ or ▼ to choose PANEL DIMMER from page 1.
4. Press ► to open the options window.
5. Choose OFF, LOW, MEDIUM or HIGH as appropriate.
6. Press the [MENU/ESC] key twice to close the menu.

1. OPERATION

1.24 Hue

The default hue setting (DAY) displays echoes in tones of gray on a white background, which is most suitable for daytime viewing. For nighttime viewing you may reverse this arrangement.

1. Press the [MENU/ESC] key to open the User menu.
2. Press ▼ to choose SYSTEM MENU.
3. Press ▲ or ▼ to choose HUE from page 1.
4. Press ► to open the options window.
5. Press ▲ or ▼ to choose DAY or NIGHT as appropriate.
6. Press the [MENU/ESC] key twice to close the menu.

1.25 Resetting Distance Run

You may reset distance run to zero as below. You need a navigator or speed log to display distance run.

1. Press the [MENU/ESC] key to open the User menu.
2. Press ▼ to choose SYSTEM MENU.
3. Press ▲ or ▼ to choose "TRIPLOG RESET?" from page 1.
4. Press ► to open the options window.
5. Press ▲ to choose YES to reset distance run to zero.
6. Press the [MENU/ESC] key twice to close the menu.

1.26 PROG Key

The [PROG] key acts as a shortcut key. You may use any User menu item except items on the "SYSTEM MENU." The default setting is TX/ST-BY.

Using the PROG key

1. Press the [PROG] key. The options window corresponding to the item programmed appears. In the example at the top on this page the echo stretch options window is shown.



Echo stretch options window

2. Press ▲, ▼ or the [PROG] key to choose appropriate option.
3. Press the [MENU/ESC] key to close the options window.

Programming the PROG key

1. Press the [MENU/ESC] key to open the User menu. The "P" mark indicates the current function of the [PROG] key.

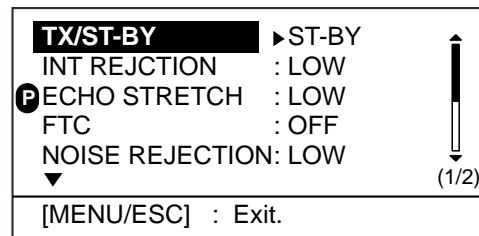

User menu, page 1

2. Press ▲ or ▼ to choose the item you wish to use.
3. Press and hold down the [PROG] key (about three seconds) until you hear a beep and the "P" moves to the item selected.
4. Press the [MENU/ESC] key to close the menu.

1.27 Outputting Target Position to a Plotter

If the radar is interfaced with a plotter, you can output a radar target's latitude and longitude position to the plotter, and show that position on the plotter's screen, with the target mark (⊗). This function requires position and heading data.

1. Use the cursor pad to place the cursor on a target.
2. Press the [TLL] key to output the target's L/L position. "Output TLL" appears at the bottom of the screen.

1.28 Turning Navigation Data On/Off

Navigation data appears on the bottom half of the screen as in the illustration below. You may turn the navigation data display on or off as shown below.

Note: When the nav data is turned on with shift or zoom active, zoom or shift is cancelled.

1. Press the [MODE] key.
2. Press **▶** to choose ON; **◀** to choose OFF.
3. Press the [MENU/ESC] key to close the menu.

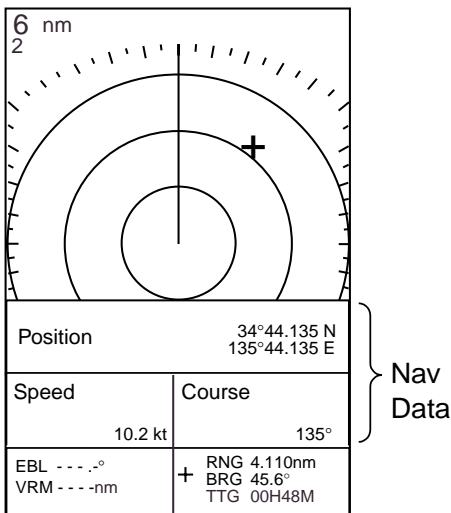

Sample navigation display

1.29 Setting up Nav Data Displays

The user may arrange the nav data display as desired. You may display between two and four items and choose the item and the order to display them. For how to choose the number of items to display, see "NAV DATA" on page 16.

1. Turn on the nav data referring to paragraph 1.28.
2. Press the [POWER/BRILL] key momentarily followed by the [MODE] key to go into stand-by.

3. Press the [MENU/ESC] key to close the window.
4. Press the cursor pad to display the nav data setup window.

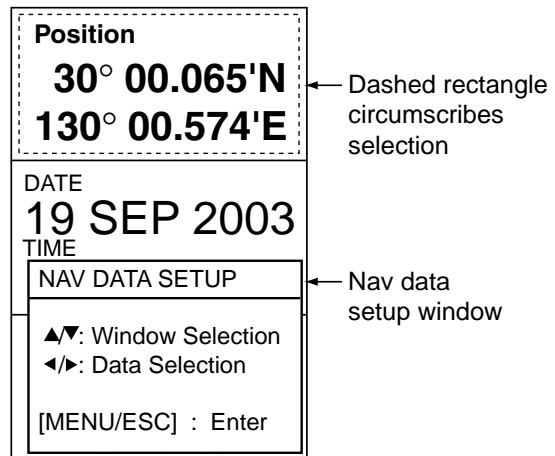

Nav data display with nav data setup window

5. Press **▲** or **▼** to choose the data window to process. The dashed rectangle circumscribes current selection.
6. Press **◀** or **▶** to choose item to display. See the illustration below for the data availability. A description of the nav data displays appears on the next page.

2-item display	3-item display	4-item display
Nav data at stand-by		
(1)	(3)	(6)
(2)	(4)	(7)
	(5)	(8)
		(9)
Nav data on radar display		
(1)	(3)	(6) (7)
(2)	(4) (5)	(8) (9)

Items displayable in (1) - (3): depth, position, course, date, time, range and bearing, trip distance, odometer distance, water temperature, heading, time-to-go to destination waypoint, XTE*, speed*, wind speed and direction*, destination waypoint data*, compass*, Time Difference

Items displayable in (4) - (9): depth, position, course, range and bearing, trip distance, odometer distance, water temperature, date, time, speed, heading, time-to-go to destination waypoint, XTE*, wind speed and direction, Time Difference

* = Graphic display in standby

Nav data window and item displayable

7. Press the [MENU/ESC] key to close the nav data setup window.

1. OPERATION

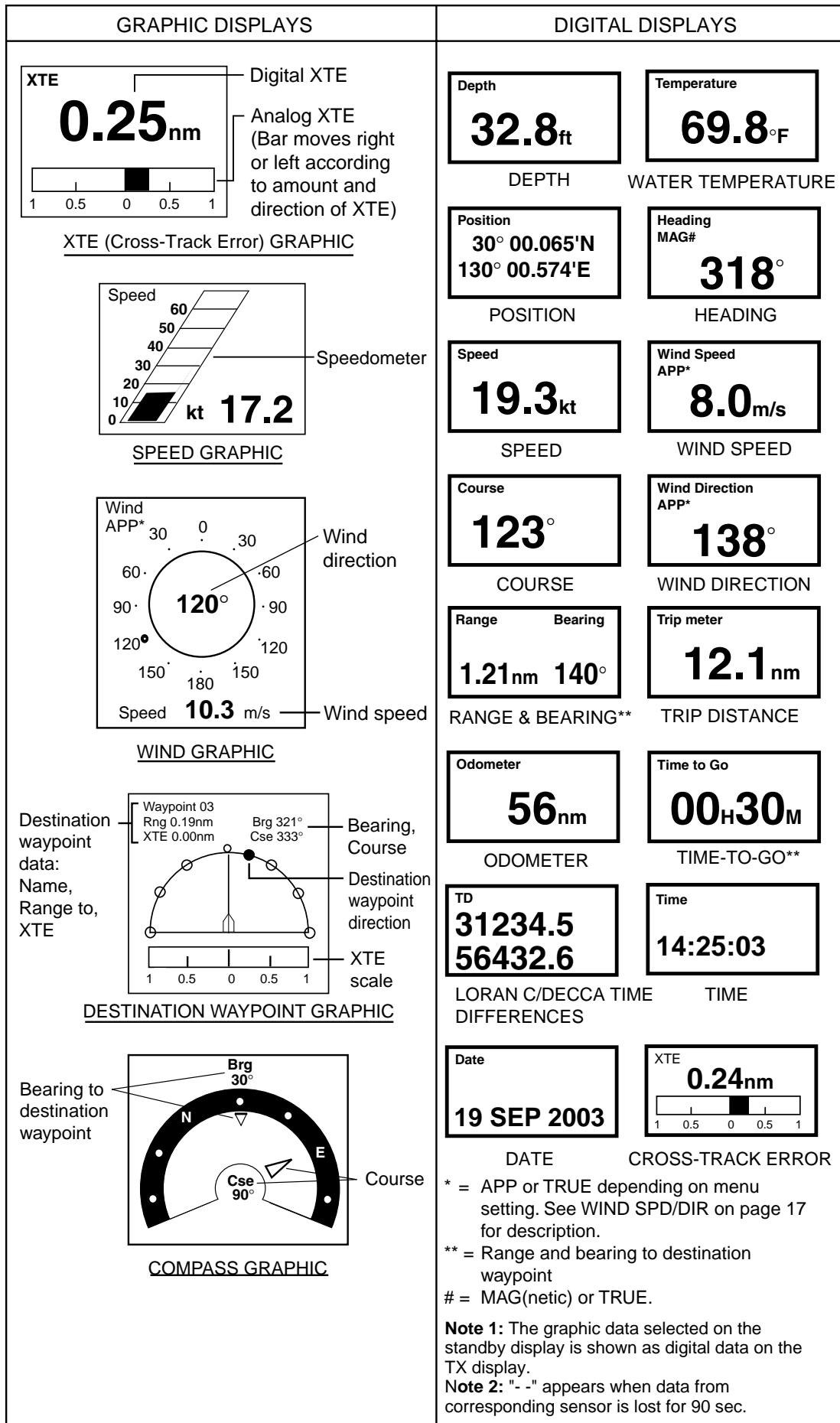

Nav data displays

1.30 System Menu

The System menu mainly contains items which once set do not require frequent adjustment. You may display this menu by choosing "SYSTEM MENU" from page 2 of the User menu and then pressing ►.

PAGE 1

SYSTEM MENU	
LANGUAGE	► English
RANGE UNIT	: nm
DEPTH UNIT	: ft
SPEED UNIT	: kt
WIND UNIT	: kt
TEMP UNIT	: °F
NAV DATA	: 
KEY BEEP	: ON
RINGS	: OFF
WAYPOINT MARK	: OFF
PANEL DIMMER	: HIGH
HUE	: DAY
TRIPLOG RESET?	: NO
[MENU/ESC] : Exit.	

(1/3)

Page no.

PAGE 2

SYSTEM MENU	
EBL REFERENCE	► TRUE
BEARING READOUT	: TRUE
CURSOR POSITION	: RNG&BRG
TRIP SOURCE	: LAT/LON
WIND SPD/DIR	: APPARENT
SHIFT MODE	: MANUAL
AUTO SHIFT SPEED	: 15
TX SECTOR BLANK	: OFF
BLANKING START	: 000°
BLANKING AREA	: 000°
LOCAL TIME SETUP	: +0:00
ANTENNA SPEED	: AUTO
[MENU/ESC] : Exit.	

(2/3)

PAGE 3

SYSTEM MENU	
RANGE 0.125nm	► ON
0.25 nm	: ON
0.5 nm	: ON
0.75 nm	: ON
1 nm	: OFF
1.5 nm	: ON
2 nm	: OFF
3 nm	: ON
4 nm	: OFF
6 nm	: ON
8 nm	: ON
12 nm	: ON
16 nm	: ON
24 nm	: ON
[MENU/ESC] : Exit.	

(3/3)

System menu

System menu description

Page 1 of system menu

LANGUAGE: The system language is available in English, several European languages and Japanese. To change the language, choose language desired, and then press the [MENU/ESC] key.

RANGE UNIT: Chooses the unit of range measurement among nautical miles, kilometers and statute miles.

DEPTH UNIT: Chooses the unit of depth measurement among meters, feet, fathoms, Hiro (Japanese) and Passi/Braza. Requires depth data.

SPEED UNIT: Chooses the unit of speed measurement among knot, mile per hour and kilometer per hour. Requires speed data. When changed, AUTO SHIFT SPEED (page 2 of system menu) is set to "15."

WIND UNIT: Chooses the unit of wind measurement among mile per hour, kilometer per hour and meters per second. Requires wind data.

TEMP UNIT: Chooses the unit of water temperature measurement from Celsius and Fahrenheit. Requires water temperature data.

NAV DATA: Chooses the amount of nav data to display among two, three and four items. Requires appropriate sensors.

KEY BEEP: A beep sounds to confirm valid and invalid operation. You can turn this beep on or off.

RINGS: Turns the range rings on or off.

WAYPOINT MARK: The waypoint mark shows the location of the destination waypoint set on a plotter. You can turn this mark on or off. Requires a plotter.

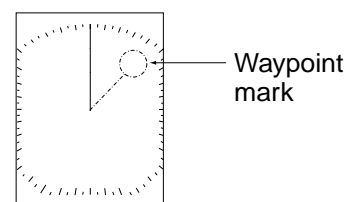

Waypoint mark

1. OPERATION

PANEL DIMMER, HUE, TRIPLOG RESET:

See paragraph 1.23, 1.24, 1.25, respectively.

Page 2 of system menu

EBL REFERENCE: The EBL readout may be chosen from relative (relative to own ship's heading) or true (referenced to the North). Heading data required for true bearing.

Note: If no bearing data is input, course data from the GPS navigator is used. In this case ship's speed must be more than two knots.

BEARING READOUT: Course indication may be shown in true or magnetic (magnetic compass) degrees. Heading data required for true degrees.

CURSOR POSITION: Chooses the information to show for the cursor position: latitude and longitude or range and bearing from own ship. Latitude and longitude position requires a navigator.

TRIP SOURCE: Chooses the criteria for calculating distance run: latitude and longitude or speed. Requires navigator or speed log.

WIND SPD/DIR: **True** is the speed and direction (in relation to ship's bow) of the wind felt or measured when stationary. **Apparent** is the direction (in relation to ship's bow) and speed of the wind as it appears to those on board, relative to the speed and direction of the boat; combination of the true wind and the wind caused by the boat's movement. Requires wind data.

SHIFT MODE: Own ship position, or sweep origin, can be displaced manually or automatically. For automatic displacement, the amount of shift is calculated with ship speed, and the amount is limited to 60% of the range in use. For example, if the "Auto Shift Speed" setting is 15 knots and the ship is running at 10 knots, the amount of shift will

be about 40%. The formula for determining shift amount is as below. Requires speed data.

$$\frac{\text{Ship's speed}}{\text{Shift speed setting}} \times 0.6 = \text{Amount of shift(\%)}$$

AUTO SHIFT SPEED: Sets the automatic shift maximum speed. The setting range is 1-99.

TX SECTOR BLANK: If the antenna is installed where an object (mast, etc.) will prevent transmission within its breadth, or transmission in area will present a health hazard, you should disable transmission within this area by turning on this feature and setting the area with BLANKING START and BLANKING AREA below.

BLANKING START: Sets the starting point (000-359°) of the TX sector blanking area.

BLANKING AREA: Sets the angle of the TX sector blanking area (000-135°).

LOCAL TIME SETUP: Enter time difference between local time and UTC time to use local time. Press ▲ or ▼ to set value.

ANTENNA SPEED: Chooses antenna rotation speed from 24 rpm and AUTO. Use AUTO to automatically change the antenna rotation speed (24 rpm for long pulse, 31 rpm for medium or 41 rpm for short). Choose "24 rpm" to rotate the antenna at 24 rpm regardless of pulse length.

Page 3 of system menu

RANGE: Chooses the ranges to use.

2. MAINTENANCE, TROUBLESHOOTING

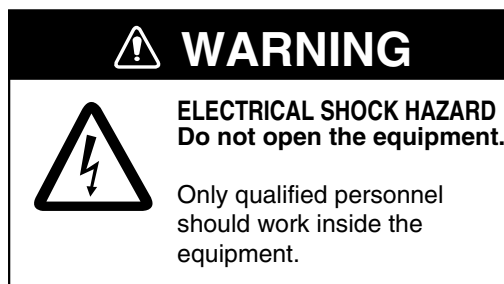

2.1 Maintenance

Regular maintenance is important for good performance. A maintenance program should be established and should at least include the items listed in the table below.

Maintenance program

Period	Item	Check point	Action
3 to 6 months	Fixing bolts for antenna unit	Check for corrosion and if tightly fastened.	Replace corroded bolts. Coat new bolts with anticorrosive sealant.
	Antenna unit cleanliness	Check for foreign material on the antenna unit. (Foreign material on the antenna unit can cause a considerable drop in sensitivity.)	Clean the antenna unit with a freshwater-moistened cloth. Alcohol may be used. Do not use commercial cleaners to clean the antenna unit; they can remove paint and markings or deform the equipment.
	Antenna unit cover	Check for cracks. Permanent damage to the unit's circuitry will result if water leaks inside.	If a crack is found, it should be temporarily repaired by using a small amount of sealing compound or adhesive. The unit should then be brought to your dealer for permanent repairs.
	Display unit case, LCD	The display case and LCD will, in time, accumulate a coating of dust, and dust on the LCD tends to dim the picture.	Wipe the LCD carefully to prevent scratching, using tissue paper and an LCD cleaner. To remove dirt or salt deposits, use an LCD cleaner, wiping slowly with tissue paper so as to dissolve the dirt or salt. Change paper frequently so the salt or dirt will not scratch the LCD. Do not use commercial cleaners to clean the display unit; they can remove paint and markings or deform the equipment.
6 months to 1 year	Display unit connectors	Check for tight connection and corrosion.	If corroded, ask your dealer about replacement.

2.2 Replacing the Fuse

The fuse (5 A) in the power cable protects the equipment against reverse polarity of the ship's mains, overcurrent, and equipment fault. If the fuse blows, find the cause before replacing it.

 CAUTION
<p>Use the proper fuse.</p> <p>Use of a wrong fuse may cause serious damage to the equipment and void the warranty.</p>

2.3 Troubleshooting

The table below provides simple troubleshooting procedures which the user can follow to restore normal operation. If you cannot restore normal operation contact your dealer for advice.

Troubleshooting

If...	But...	Then...
you pressed the [POWER/BRILL] key to turn on the radar	display contrast is poor	<ul style="list-style-type: none"> try adjusting LCD contrast. (See page 4.)
	nothing appears on the display	<ul style="list-style-type: none"> battery may have discharged; check battery. check if fuse has blown.
	the control panel does not light	adjust PANEL DIMMER on page 1 of system menu.
the radar has warmed up and you pressed the [MODE] key to transmit	the message "NO HEADING PULSE" or "NO BEARING PULSE" appears	check that the antenna cable is firmly connected.
	neither noise or targets appear (characters and markers do)	<ul style="list-style-type: none"> try adjusting gain, A/C SEA and A/C RAIN. check antenna cable for damage.
a key is pressed	nothing happens	key may be faulty. Contact your dealer.
the display freezes		press the [POWER/BRILL] key about five seconds to turn off the power and then turn it on again.

2.4 Diagnostics

If you feel that your unit is not working properly, conduct the appropriate diagnostic test, display unit or antenna unit, to find the possible cause. If you cannot restore normal operation, contact your dealer for advice.

Display unit

1. Turn on the power while pressing and holding down the [MENU/ESC] key. Continue pressing the [MENU/ESC] key until the Installation menu appears.

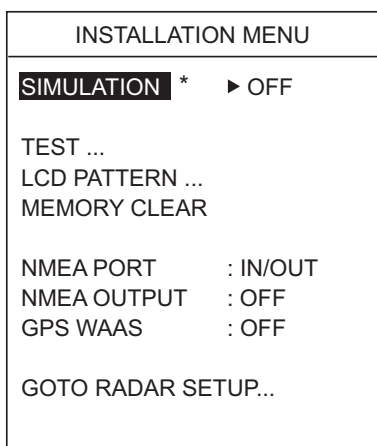

* The simulation provides internally generated echoes, for use in exhibitions, etc. "SIM" appears at the top left corner when the simulation mode is active.

Installation menu

2. Press ▼ to choose TEST.
3. Press ► to start the test. In a few moments the results will appear.

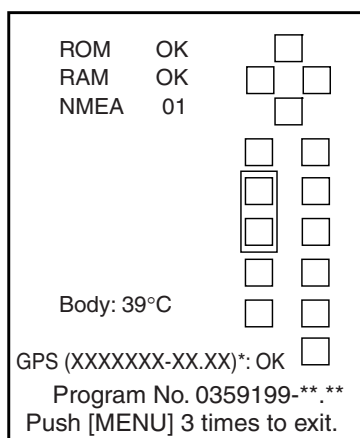

* Program no. of FURUNO BlackBox GPS
 GP-310B: 48502180XX } XX = Program
 GP-320B: 48502380XX } Version No.
 **. ** = Program version no.

Diagnostic test results

Interpreting display unit test results

Item	Results
ROM, RAM	OK: Normal NG: No Good
NMEA	Test connector required to test. Normally, "01" is displayed.
Body	Temperature of display unit
GPS	Shows program no. of GP-310B or GP-320B (if connected) and GPS status. "OK" shown for normal; no indication if abnormal.

4. The squares at the right side of the test results display are for checking controls. Press each key and the arrows on the cursor pad one by one. A control's corresponding on-screen square "lights" in black if the control is working properly.
5. To return to the Installation menu, press the [MENU/ESC] key three times.
6. To restore normal operation, turn off the power and then turn it on again.

Antenna unit

1. Display the installation menu as in step 1 in the display unit diagnostic test.
2. Press ▼ to choose GOTO RADAR SETUP and then press ►. Power is automatically reset.
3. Press the [POWER/BRILL] and [MODE] keys to transmit.
4. Press the [MENU/ESC] key. The menu below appears.

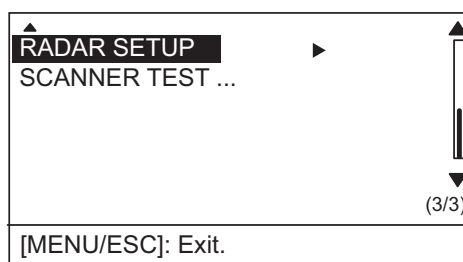

Page 3/3 of user menu

5. Press ▼ to choose SCANNER TEST.
6. Press ► to start the test. In a few moments the results will appear, similar to those shown at the top of the next page.
7. To restore normal operation, turn off the power and then turn it on again.

2. MAINTENANCE, TROUBLESHOOTING

ANTENNA STATUS	: OK(47)#
HEADING	: OK
BEARING	: OK
	(24.0rpm)*
TUNE	: 
TOTAL ON TIME	: 00000h
TOTAL TX TIME	: 00000h
INPUT NMEA	
RMA RMB RMC BWC GLL GGA	
MTW VTG VHW XTE VBW DPT	
DBK DBS DBT HDT HDG HDM	
BWR GLC GTD MWV ZDA	
[MENU/ESC]: Exit.	

Numeric is status code. For service technician.

* Antenna rotation speed

24.0 = Long range

31.0 = Medium range } typical

41.0 = Short range } value

Antenna test results

The antenna unit and heading and bearing signals are checked, and the results shown as OK or NG (No Good). For any NG, contact your dealer for advice. Antenna unit RPM appears below the bearing signal test result.

Note: The result of ANTENNA STATUS is shown as “NG (0)” when the antenna test result screen is initially shown. To confirm the antenna status, press the [MENU/ESC] key and ►.

The “TUNE” bar shows radar receiver tuning status. Total on time and total TX times appear below the TUNE bar. Data sentences currently input to the radar are highlighted in the “INPUT NMEA” window.

2.5 Test Pattern

This feature tests for proper display of tones.

1. Turn on the power while pressing and holding down the [MENU/ESC] key. Continue pressing the [MENU/ESC] key until the Installation menu appears.
2. Press ▼ to choose LCD PATTERN.
3. Press ► to start the test. The entire screen is black.
4. Press the [MENU/ESC] key and the screen turns white.

5. Press the [MENU/ESC] key again and the screen shows a four-tone display.
6. Press the [MENU/ESC] key again to return to the Installation menu.
7. To restore normal operation, turn off the power and then turn it on again.

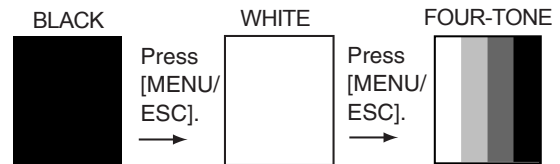

Test patterns

2.6 Clearing the Memory

You may want to clear the memory to start afresh with default settings. You can do this as follows:

1. Turn on the power while pressing and holding down the [MENU/ESC] key. Continue pressing the [MENU/ESC] key until the Installation menu appears.
2. Press ▼ to choose MEMORY CLEAR.
3. Press ►.
4. Press ▲ to choose YES.
5. To clear the memory turn the power off and on again.

2.7 Replacing the Magnetron

When the magnetron has expired, distant targets cannot be seen on the display. When you feel that long range performance has decreased, contact a FURUNO agent or dealer about replacement of the magnetron. (Type: E3588, Code No: 000-142-270)

2.8 Replacing the Synchro Belt

When the synchro belt has worn out, the sweep is not synchronized with antenna rotation, which results in an abnormal picture. When you suspect that the synchro belt has worn out, contact a FURUNO agent or dealer about replacement. (Type: 40 S2M 266UG, Code No: 000-808-743)

3. INSTALLATION

NOTICE

Do not apply paint, anti-corrosive sealant or contact spray to coating or plastic parts of the equipment.

Those items contain organic solvents that can damage coating and plastic parts, especially plastic connectors.

3.1 Antenna Unit Installation

Mounting considerations

When choosing a mounting location for the antenna unit, keep in mind the following points:

- Install the antenna unit on the hardtop, radar arch or on a mast on an appropriate platform. (For sailboats, a mounting bracket is optionally available.) It should be placed where there is a good all-round view with, as far as possible, no part of the ship's superstructure or rigging intercepting the scanning beam. Any obstruction will cause shadow and blind sectors.
- In order to minimize the chance of picking up electrical interference, avoid where possible routing the antenna cable near other electrical equipment onboard. Also, avoid running the cable in parallel with power cables.
- Separate the antenna unit from a magnetic compass by the distances noted below to prevent interference to the magnetic compass:
 - Standard compass: 1.25 m
 - Steering compass: 0.85 m

Mounting on a platform

1. Remove mounting hardware at the bottom of the antenna unit; four each of hex bolts (M10X20), spring washers and flat washers. Save mounting hardware to use it to fix the antenna unit to the mounting platform later on.

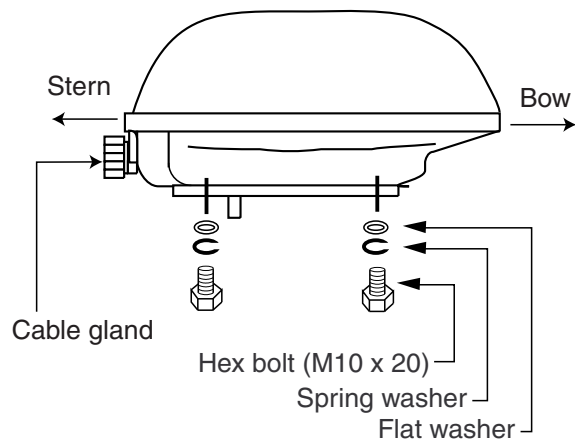

Antenna unit, showing location of mounting hardware

2. Construct a wood, steel or aluminum platform on which to fix the antenna. (The thickness of the platform depends on the hex bolts to be used to fix the antenna to the platform. See the illustration on the next page for thickness.) Next, position the antenna unit so the cable gland faces toward boat's stern.

Note 1: If corrosive material is used for the platform, take appropriate anticorrosive measures to prevent corrosion.

Note 2: When drilling holes in the platform, be sure they are parallel with the fore and aft line.

3. INSTALLATION

- Use the flat washers and spring washers removed earlier and appropriate hex bolts (see the illustration below) to fasten the antenna unit to the platform. **The torque should be between 19.6-24.5 N/m.**

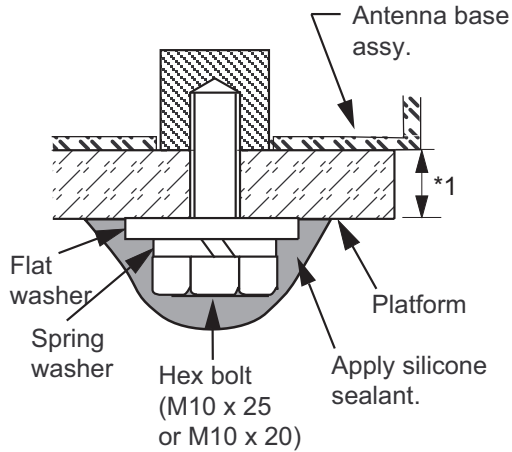

*1: Platform thickness	Bolt to use
5 mm or less:	M10 x 20
5-10 mm:	M10 x 25
over 10 mm:	locally supplied bolts

How to fasten the antenna base to platform

- Unfasten four screws to open the cover. Remove and discard the packing material inside the radome.

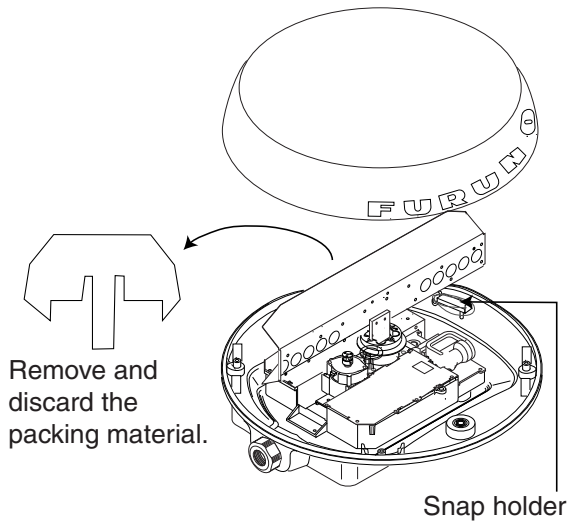

Antenna unit, inside view

The antenna base is fitted with a snap holder, which may be used to hang the cover after removal. Use the hole next to the screw hole inside the cover to hang it.

- Unfasten the snap assy. with the string attached at the holder in the antenna base.
- Unwind the string.
- Attach the snap to the screw hole on the inside of the cover.

Note: Do not use the snap holder to hang objects other than the cover.

- Release the cable of the rotation detector from the cable clamp.
- Unfasten 11 screws to dismount the shield plate.

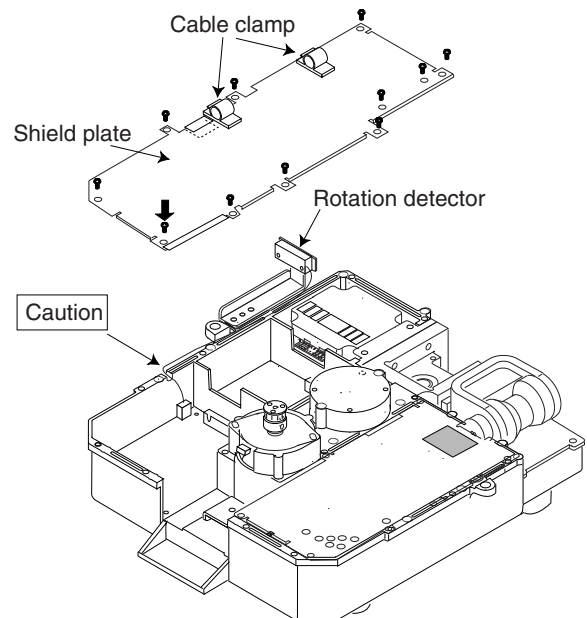

- Pass the antenna cable with connector through the gasket and cable clamp, and then tighten the cable gland.

Note: Two gaskets are supplied: one gray, one black. Use the proper gasket according to antenna cable used, referring to the illustration below.

Antenna cable and gasket to use

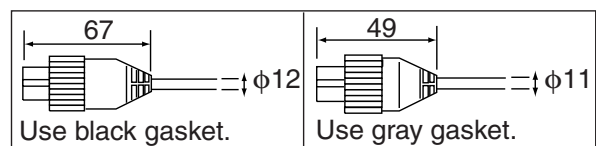

8. Tighten the cable gland to fix the antenna cable.

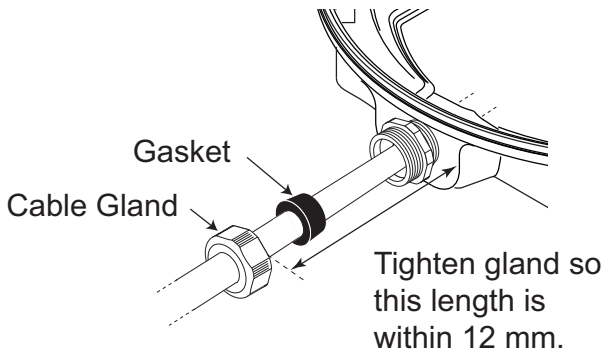

Antenna unit, inside view

9. Referring to the figure below, fasten the shield cable with a screw (M4 x 10) on the chassis to ground the unit.

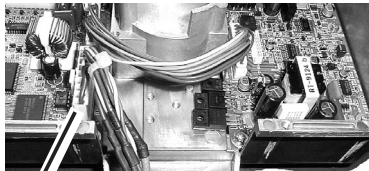

Connect 9 pin connector here (J801).

Connect shield here.

Connecting antenna cable to antenna unit

10. Attach the EMI core to the antenna cable. Set the EMI core fixing band to the EMI core.

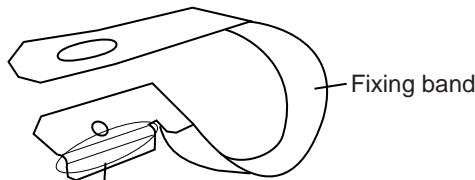

This bend should be facing to the cable entrance.

EMI core fixing band

11. Connect the 9-pin connector of the antenna cable to J801. See the illustration on the previous page for location.
 12. Refasten the shield plate with 10 screws. Be sure not to pinch the cable from the rotation detector with the shield plate.

13. Fasten the EMI core fixing plate with screw (supplied).

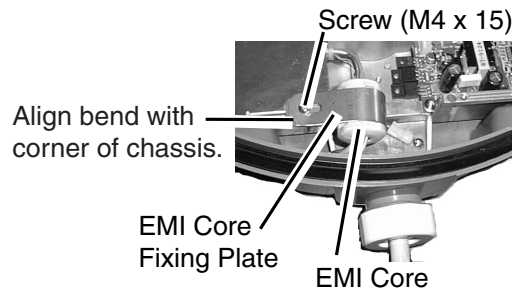

How to fix the EMI core

14. Temporarily close the cover. You will need to open the cover later to confirm magnetron voltage.

Mounting using the optional mounting bracket

A mounting bracket for fastening the antenna unit to a mast (70-125 mm diameter) on a sailboat is optionally available.

Type OP03-93, Code 008-445-080

Contents of radome mounting assy.

Name	Type	Code No.	Qty
Bolt	M4 x 12	000-804-725	4
Bolt	M8 x 20	000-805-707	8
Mounting plate	03-018-9001-0	100-206-740	1
Support plate (1)	03-018-9005-0	100-206-780	1
Support plate (2)	03-018-9006-0	100-206-790	1
Bracket (1)	03-028-9101-0	100-206-810	1
Bracket (2)	03-028-9102-0	100-206-820	1
Fixing plate	03-028-9103-0	100-206-830	2

1. Remove mounting hardware at the bottom of the antenna base. You may discard the mounting hardware.
2. Assemble the mounting bracket as below and fasten it to a mast.
3. Fasten the antenna unit to the mounting bracket with hexagon head bolts (M10 x 25).

3. INSTALLATION

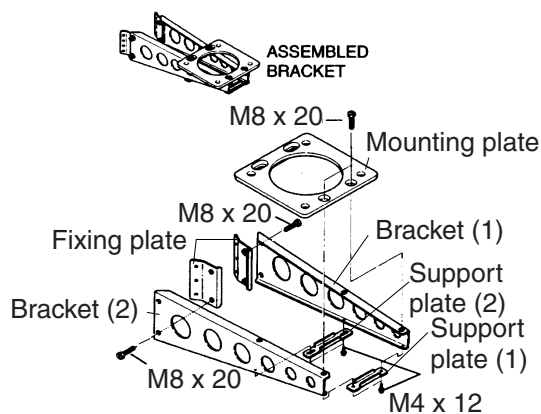

(A) Assembling the mounting bracket

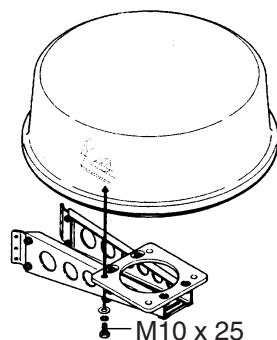

(B) Fastening antenna to mounting bracket

How to assemble the optional mounting bracket and mount the antenna

4. Open the cover.
5. Follow steps 5-13 in "Mounting on a platform."

3.2 Display Unit Installation

Mounting considerations

When choosing a mounting location for the display unit, keep in mind the following points:

- Keep the display unit out of direct sunlight.
- The temperature and humidity should be moderate and stable.
- Locate the unit away from exhaust pipes and vents.
- The mounting location should be well ventilated.
- Mount the unit where shock and vibration are minimal.

- Keep the unit away from electromagnetic field-generating equipment such as motors and generators.
- For maintenance and checking purposes, leave sufficient space at the sides and rear of the unit and leave slack in cables.
- Separate the display unit from a magnetic compass unit by the distances noted below to prevent interference to the magnetic compass:
 - Standard compass: 0.60 m
 - Steering compass: 0.40 m
- Be sure the mounting location is strong enough to support the weight of the unit under the continued vibration normally experienced on the boat.

Mounting

The display unit can be mounted on a desktop, overhead or bulkhead, or flush mounted in a console.

Desktop, overhead mounting

1. Fix the hanger to the mounting location with four tapping screws (supplied).
2. Fit the knob bolts to the display unit.
3. Set the display unit to the hanger.
4. Tighten the knob bolts securely.

Flush mounting

Cutout a hole in the mounting area, referring to the template provided. Fasten the display unit with four screws (M4 x 20, supplied).

Bulkhead mounting

Using the template sheet provided, make four holes ($\Phi 4.5$) in the mounting location to fix the hanger.

3.3 Wiring

Connect the antenna cable, the power cable and the ground wire as shown below.

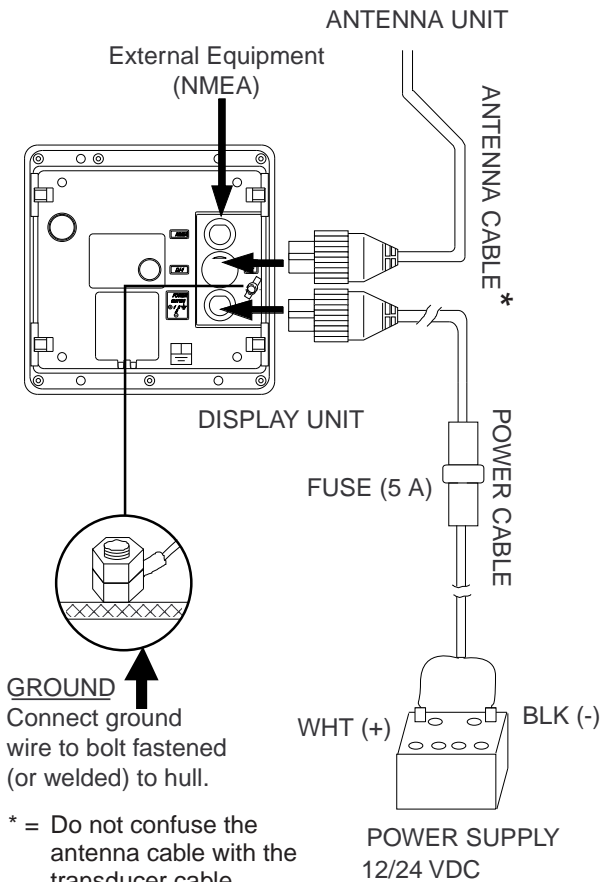

GROUND
Connect ground wire to bolt fastened (or welded) to hull.

* = Do not confuse the antenna cable with the transducer cable for the Echo Sounder (ex. LS-6100). The transducer cable is black; the antenna cable is white and "RADAR" is written on the cable.

Wiring

Connecting external equipment

A video sounder, navigator, plotter, wind indicator or GPS receiver GP-310 (320B) can be connected to the display unit. You will need an NMEA cable to make the connection.

To connect two navigators, use the optional cable MJ-A15A7F0004-005. Connect them referring to the interconnection diagram at the back of this manual.

Input sentences

NMEA 0183 Version 1.5/2.0/3.0, 4800 bps

Name	Sentences
Ship's Speed	VTG>RMC>RMA>VBW>VHW
Depth	DPT>DBK>DBS>DBT
Heading (T)*	HDT>HDG>VHW>HDM
Heading (M)	HDM>HDG>VHW>HDT
Course (T)	VTG>RMC>RMA
Course (M)	VTG>RMC>RMA
Range/Bearing	RMB>BWR>BWC
Waypoint	RMB>BWR>BWC
Own Ship Pos.	GGA>RMC>RMA>GLL
Time Diff.	RMA>GLC>GTD
Water Temp.	MTW
Time, Date	ZDA>RMC
Wind Data	MWV
Cross-track Error	RMB>XTE

*Requires magnetic variation (output by navigator).

Output sentence

NMEA 0183 Version 3.0, 4800 bps

Name	Sentence
Target L/L	TLL

3. INSTALLATION

Connecting the external buzzer

The optional external buzzer (type XH3-BZ-L970, code no. 000-146-422) sounds the alarm buzzer in a remote location.

Note: This procedure requires making a hole in the display unit, which can affect watertightness. FURUNO cannot guarantee watertight integrity after this modification is made.

1. Detach the rear panel and place it out side up on a workbench.
2. Use a hammer and a Philips head screwdriver to punch out a hole of $\varnothing 16$ at the location shown in the illustration below.

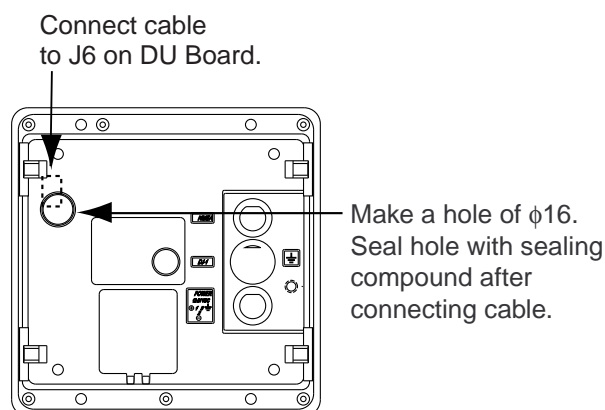

Display unit, rear view

3. Close the rear panel, making sure the gasket is correctly positioned.
4. Plug in the connector of the external buzzer to J6 on the DU Board.
5. Seal the hole with sealing compound.
6. Fix the buzzer to the location desired with two tapping screws.

3.4 Adjustments

After you have installed the radar, do the heading alignment and timing adjustment. If you are connecting external equipment, follow "NMEA port setup, GPS WAAS setup" (for GP-320B) also.

Heading alignment

You have mounted the antenna unit facing straight ahead in the direction of the bow. Therefore, a small but conspicuous target dead ahead visually should appear on the heading line (zero degrees).

In practice, you will probably observe some small error on the display because of the difficulty in achieving accurate initial positioning of the antenna unit. The following adjustment will compensate for this error.

1. Turn on the power while pressing and holding down the [MENU/ESC] key. Continue pressing the [MENU/ESC] key until the Installation menu appears.

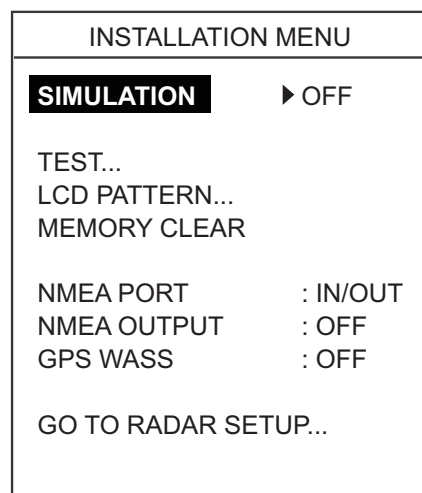

Installation menu

2. Press ▼ to choose GOTO RADAR SETUP.
3. Press ►. Power is then reset.
4. Wait one minute, press the [POWER/BRILL] key followed by the [MODE] key to transmit.
5. Press the [MENU/ESC] key to show the User menu.

6. Press ► to show the Radar Setup menu.

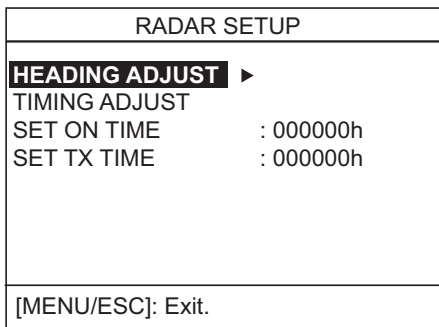

Radar setup menu

7. HEADING ADJUST is selected; press ► to show the options window.

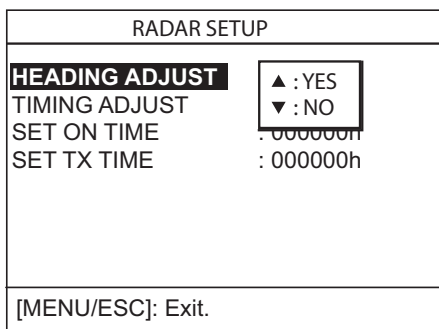

Radar setup menu (heading adjust)

8. Press ▲ to choose YES, and the display now looks as below.

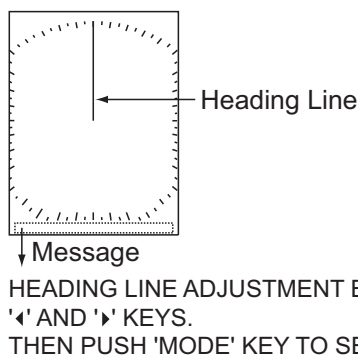

Heading adjustment display

9. Visually identify a suitable target (for example, ship or buoy) at a range between 0.125 to 0.25 miles.
 10. Point your boat's bow directly toward the target selected at step 9.
 11. Locate the target selected at step 9 on the display and choose a range which places it in the outer half of the picture.
 12. Press ◀ or ▶ to bisect the target with the heading line.

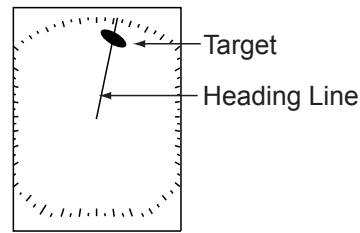

Heading adjustment display

13. Press the [MODE] key.
 14. Press the [MENU/ESC] key twice to close the menu.
 15. Move the boat towards a small buoy and confirm that the buoy shows up dead ahead on the radar when it is visually dead ahead.

Timing adjustment

Sweep timing differs with respect to the length of the antenna cable. Adjust sweep timing to prevent pushing or pulling of the target as illustrated below and placement of targets at incorrect ranges.

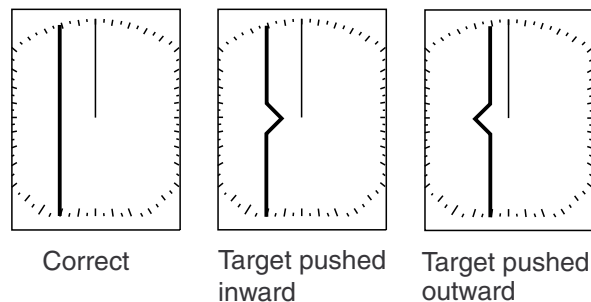

Improper and correct sweep timings

1. Transmit on a range between 0.125 and 0.5 nm and adjust the sensitivity and A/C SEA. (See page 4 and 5 for procedure.)
 2. Choose TIMING ADJUST from the Radar Setup menu and press ►.

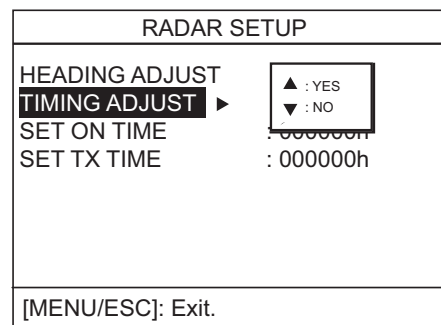

Radar setup menu (timing adjust)

3. INSTALLATION

3. Press ▲ to choose YES, and the display now looks as below.

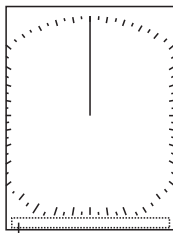

Message
SWEEP TIMING ADJUSTMENT BY
'▲' AND '▼' KEYS.
THEN PUSH MODE KEY TO SET.

Timing adjustment display

4. Find a target which should be “straight” (harbor wall, straight pier) on the radar display.
5. While looking at the target selected at step 4, straighten it by pressing ▲ or ▼.
6. Press the [MODE] key.
7. Press the [MENU/ESC] key and then complete the procedure below if you are going to connect external equipment, or shut off the power if no external equipment is connected.

NMEA port setup, GPS WAAS setup

The NMEA port can function as an input port or input/output port.

If you are using the GP-320B, turn on the GPS WAAS feature.

1. Show the Installation menu and then press ▼ to choose NMEA PORT.
2. Press ► to display the NMEA port options window.
3. Press ▲ or ▼ to choose IN/OUT or IN/IN as appropriate.

IN/OUT: Input and Output (default setting). For GP-310B or GP-320B, choose this setting.

IN/IN: Input only (Available with connection of multiple navigators.)

4. If you selected IN/OUT at step 3, press ◀, ▼ to choose NMEA OUTPUT, and then press ► to display the NMEA OUTPUT options window.
5. Press ▲ or ▼ to choose OFF or ON. Choose ON to output input data. Choose OFF to not output data or if the GP-310B or GP-320B is connected.
6. Press ◀ to close the window.
7. If the GP-320B is connected, press ▼ to choose GPS WAAS and then complete steps 8-10. Otherwise, go to step 10.
8. Press ► to open the window.
9. Press ▲ to choose message type.

Note: WAAS is currently in the developmental stage. While in the developmental stage choose message type 02. Change to message type 00 when WAAS becomes fully operational.

10. Turn off the power.

3.5 Magnetron Heater Voltage

Magnetron heater voltage is formed at the MD Board of the antenna unit and is preadjusted at the factory. Therefore, no adjustment is required. However, verify the voltage as below.

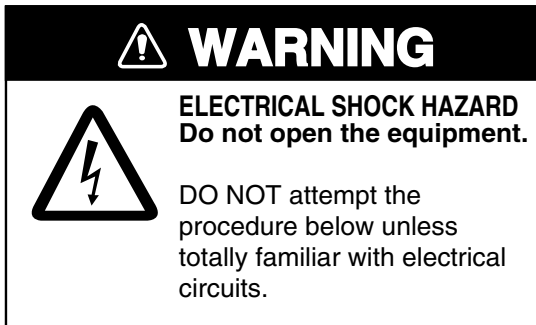

1. Open the antenna cover and open the shield plate.
2. Turn on the power. **DO NOT transmit.**
3. Connect a multimeter, set to 10 VDC range, between #6 (+) and #4 (-) of test point TP804 on the MD Board.

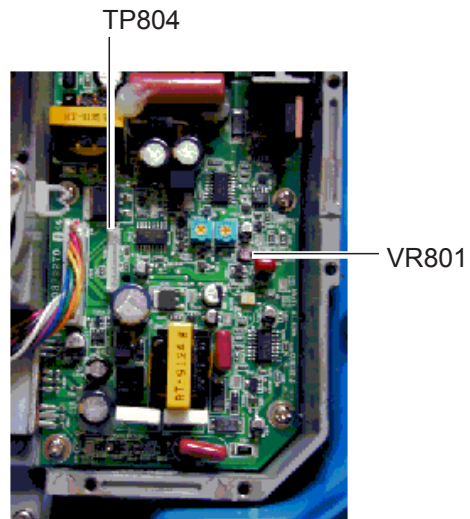

MD board

4. Confirm that the multimeter shows 8.0 V ± 0.1 V. If it does not, adjust potentiometer VR801 on the MD Board.
5. Turn off the power.
6. Fasten the shield plate.
7. Close the antenna cover.

MENU TREE

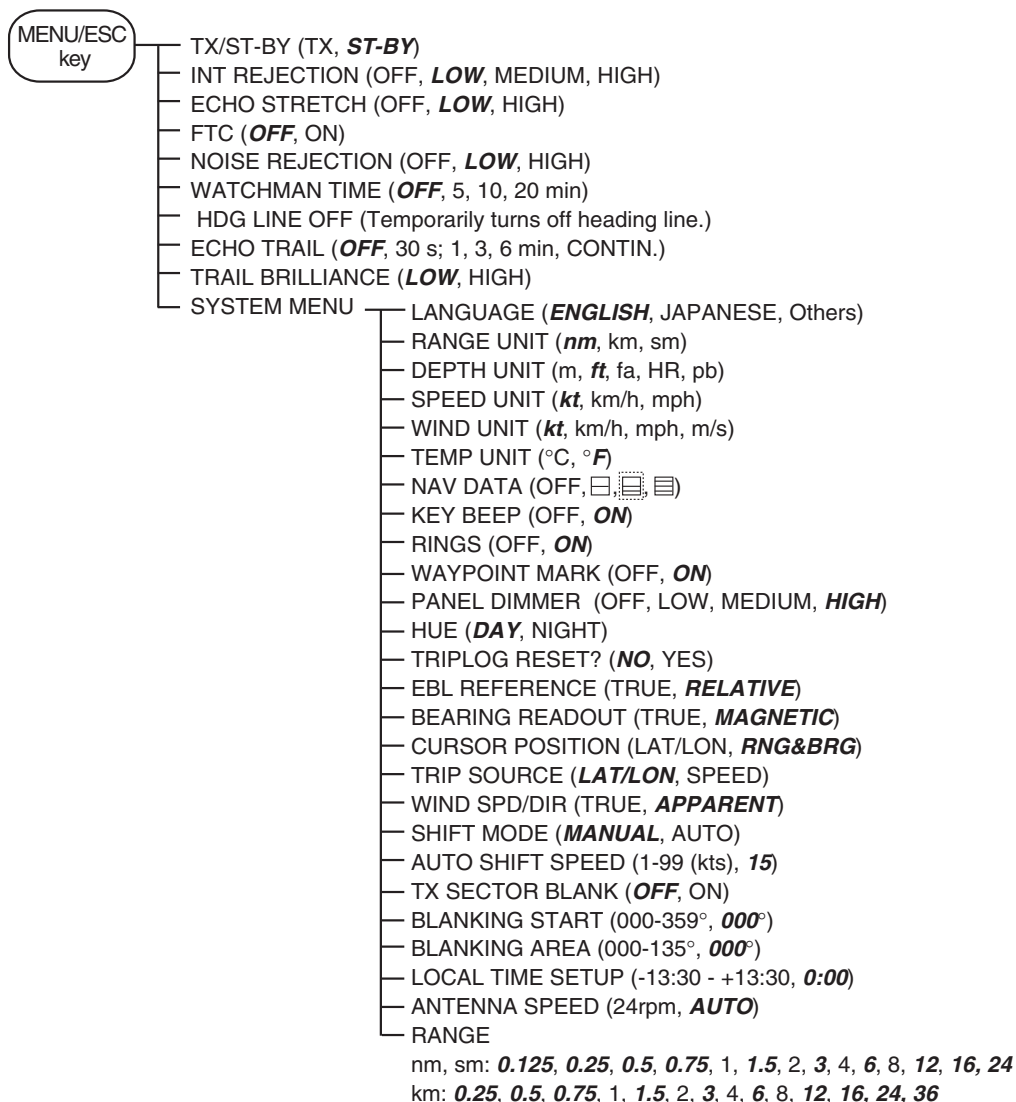

Turn on power

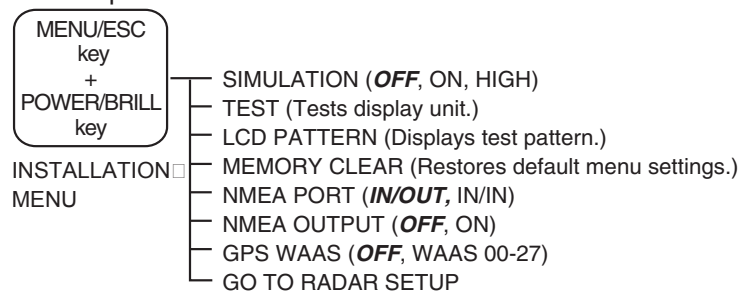

Choose GO TO RADAR SETUP from the INSTALLATION menu, and then go to page 3 of the USER menu.

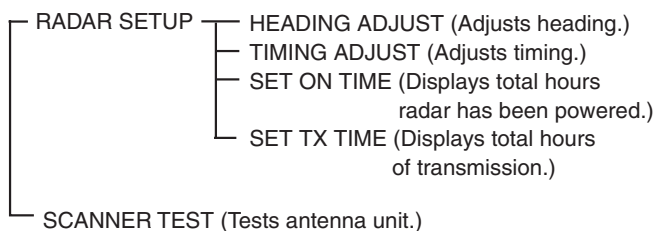

SPECIFICATIONS OF MARINE RADAR MODEL 1715

1 GENERAL

- 1.1 Indication System PPI daylight display, raster scan, 4 tones in monochrome
 1.2 Range (shown: nm), Pulselength (PL) & Pulse Repetition Rate (PRR)

Range	0.125, 0.25, 0.5, 0.75	1, 1.5, 2	3, 4, 6, 8, 12, 16, 24, 36
Pulse Length	0.08 μ s (short)	0.3 μ s (medium)	0.8 μ s (long)
Pulse Repetition Rate	3000 Hz nominal	1200 Hz nominal	600 Hz nominal

- 1.3 Range Resolution 18 m
 1.4 Bearing Discrimination 5.2°
 1.5 Minimum Range 30 m
 1.6 Bearing Accuracy Within 1°
 1.7 Range Ring Accuracy 1.0 % of range or 8 m, whichever is the greater

2 ANTENNA UNIT

- 2.1 Radiator Micro-strip
 2.2 Polarization Horizontal
 2.3 Antenna Rotation Speed 24/31/41 rpm nominal (auto-select according to range)
 2.4 Radiator Length 45 cm
 2.5 Horizontal Beamwidth 5.2° typical
 2.6 Vertical Beamwidth 25°
 2.7 Sidelobe Attenuation Less than -20 dB

3 TRANSCEIVER MODULE

- 3.1 Frequency 9410 MHz \pm 30MHz (X-band)
 3.2 Modulation P0N
 3.3 Peak Output Power 2.2 kW
 3.4 Modulator FET Switching Method
 3.5 Intermediate Frequency 60 MHz
 3.6 Tuning Automatic
 3.7 Receiver Front End MIC (Microwave IC)
 3.8 Bandwidth 15 MHz (short pulse), 5 MHz (medium/long pulse)
 3.9 Duplexer Circulator with diode limiter
 3.10 Warm-up Time 1-min. approx.

4 DISPLAY UNIT

- 4.1 Picture Tube 7" rectangular monochrome LCD
 4.2 Display Pixels 240(H) x 320(V) dots,
 Effective radar display area: 240x240 dots
 4.3 Range, Range Interval, Number of Rings

Range (nm/km)	0.125	0.25	0.5	0.75	1	1.5	2	3	4	6	8	12	16	24	36
Ring Interval	0.0625	0.125	0.125	0.25	0.25	0.5	0.5	1	1	2	2	3	4	6	12
Number of Rings	2	2	4	3	4	3	4	3	4	3	4	4	4	4	3

Range unit: nm/sm/km selectable, 0.125: nm/sm only, 36: km only

- | | | |
|-----|--------------------------|--|
| 4.4 | Markers | Heading Line, Bearing Scale, Range Rings, Variable Range Marker (VRM), Electronic Bearing Line (EBL), Cursor, Alarm Zone, Waypoint Mark* |
| 4.5 | Alphanumeric Indications | Range, Range Ring Interval, Interference Rejection (IR), Variable Range Marker (VRM), Electronic Bearing Line (EBL), Stand-by (ST-BY), Guard Alarm (G (IN), G (OUT), UP RANGE), Echo Stretch (ES), Range and Bearing to Cursor, Bearing or L/L Position, Echo Trail (TRAIL), Trail Time, Watchman (WATCH), Zoomed Display (ZOOM), Navigation Data*, Heading* *: External data required |
| 4.6 | Input Sentences | IEC 61162, NMEA 0183 (Ver1.5/2.0/3.0) GGA, RMC, RMA, RMB, GLL, VTG, VBW, VHW, HDT, HDG, HDM, BWR, BWC, GLC, GTD, DPT, DBK, DBS, DBT, MTW, ZDA, MWV, XTE |
| 4.7 | Output Sentences | IEC 61162, NMEA 0183 (Ver3.0)
TLL (by key operation) |

5 ENVIRONMENTAL CONDITIONS

- | | | |
|-----|---------------------|---|
| 5.1 | Ambient Temperature | Antenna Unit: -25°C to +55°C, Display Unit: -15°C to +55°C |
| 5.2 | Relative Humidity | 93% or less at +40°C |
| 5.3 | Waterproofing | Antenna Unit: IPX6
Display Unit: IPX5 (IPX0 when an external buzzer installed) |
| 5.4 | Bearing Vibration | IEC 60945 |

6 POWER SUPPLY

12-24 VDC: 3.5-1.6 A

7 COATING COLOR

- | | | |
|-----|--------------|-----------------------------------|
| 7.1 | Display Unit | N3.0 |
| 7.2 | Antenna Unit | Cover: N9.5, Bottom: 2.5PB 3.5/10 |

8 COMPASS SAFE DISTANCE

- | | | | |
|-----|--------------|------------------|------------------|
| 8.1 | Display Unit | Standard: 0.60 m | Steering: 0.40 m |
| 8.2 | Antenna Unit | Standard: 1.25 m | Steering: 0.85 m |

表2 TABLE 2

MODEL	MASS (kg ±0.1%)
RSB-0087/0087A/110	4.9
RSB-0094	5.2
RSB-0095	5.1

表1 TABLE 1

寸法区分(mm)	公差(mm)
DIMENSIONS	TOLERANCE
0 < L ≤ 50	±1.5
50 < L ≤ 100	±2.5
100 < L ≤ 500	±3

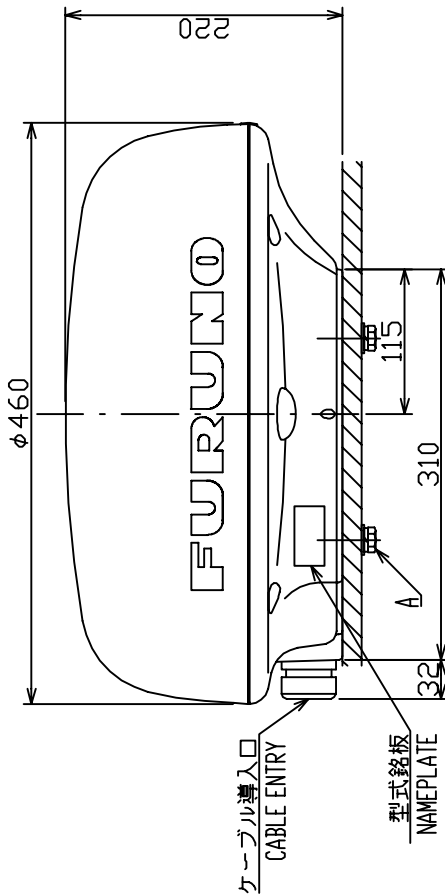
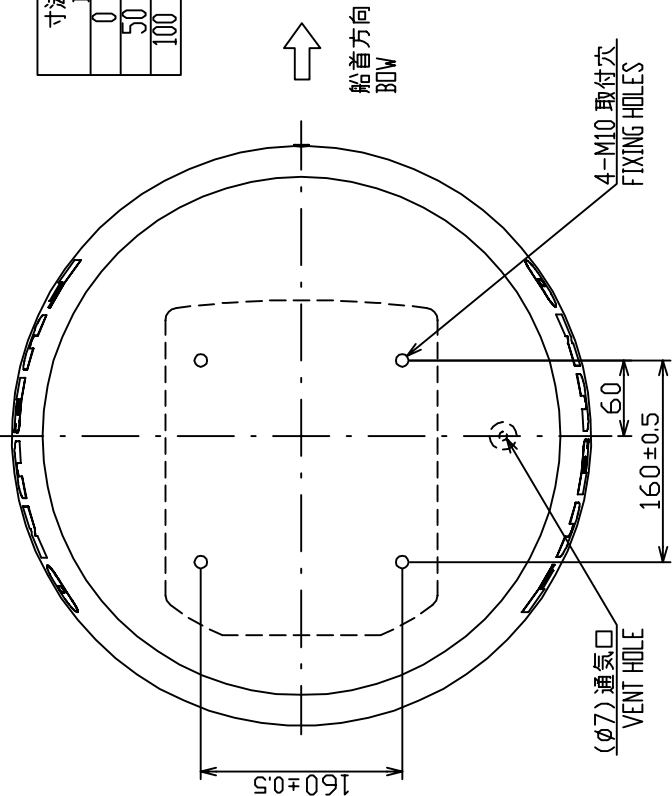
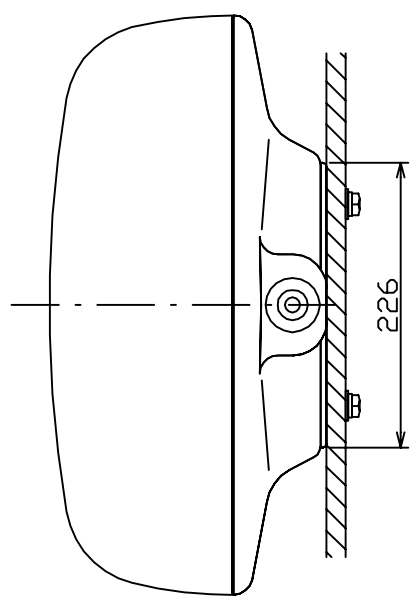
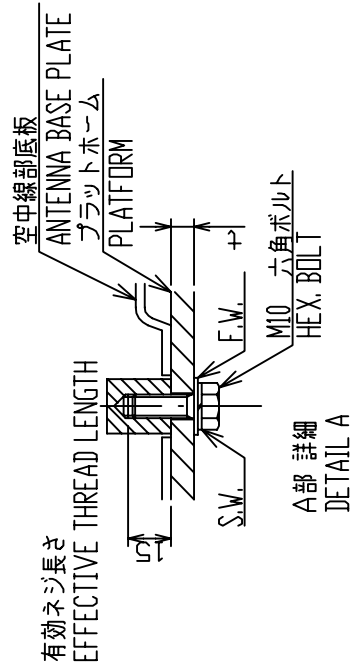

注記 1) 指定外の寸法公差は表1による。

2) 取付はM10ボルトを使用のこと。

ネジ長さは板厚に依りて、20 (t ≤ 5) または 25 (5 < t ≤ 10) とする。

NOTE 1. TABLE 1 INDICATES TOLERANCE OF DIMENSIONS WHICH IS NOT SPECIFIED.

2. USE M10 BOLTS FOR FIXING UNIT.

SCREW LENGTH SHALL BE ACCORDING TO PLATFORM THICKNESS;

20 (t ≤ 5) OR 25 (5 < t ≤ 10).

DRAWN	MODEL 1724C	TITLE	RSB-0087/0087A/0094/0095/110
CHECKED	MODEL 1824C/1824C-BB	名称	空中線部
APPROVED	MODEL 1715 TAKAHASHI, I	外寸図	
SCALE	MODEL 1823C Y. Hatai	NAME	ANTENNA UNIT
DWG No.	MODEL 1722/1722C/1723C 1/6 MASS TABLE 2	OUTLINE DRAWING	
	03-161-100G-3/03-164-300G-1		

寸法区分 (mm) DIMENSION	公差 (mm) TOLERANCE
$L \leq 50$	± 1.5
$50 < L \leq 100$	± 2.5
$100 < L \leq 500$	± 3

表 1 TABLE 1

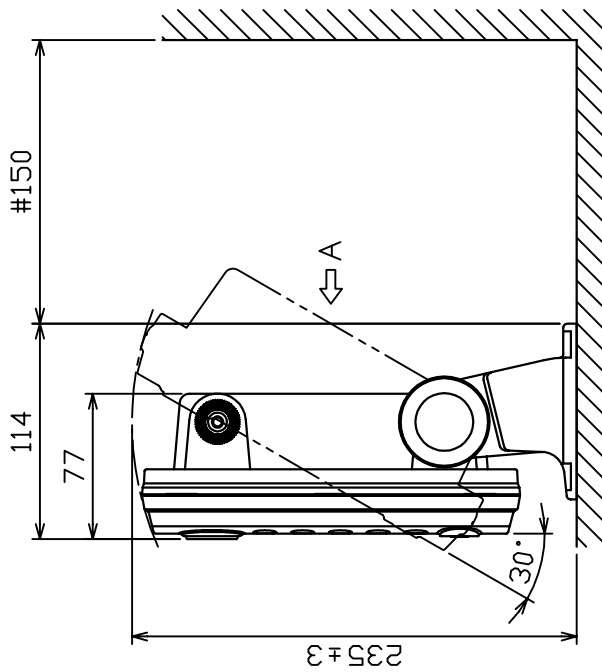
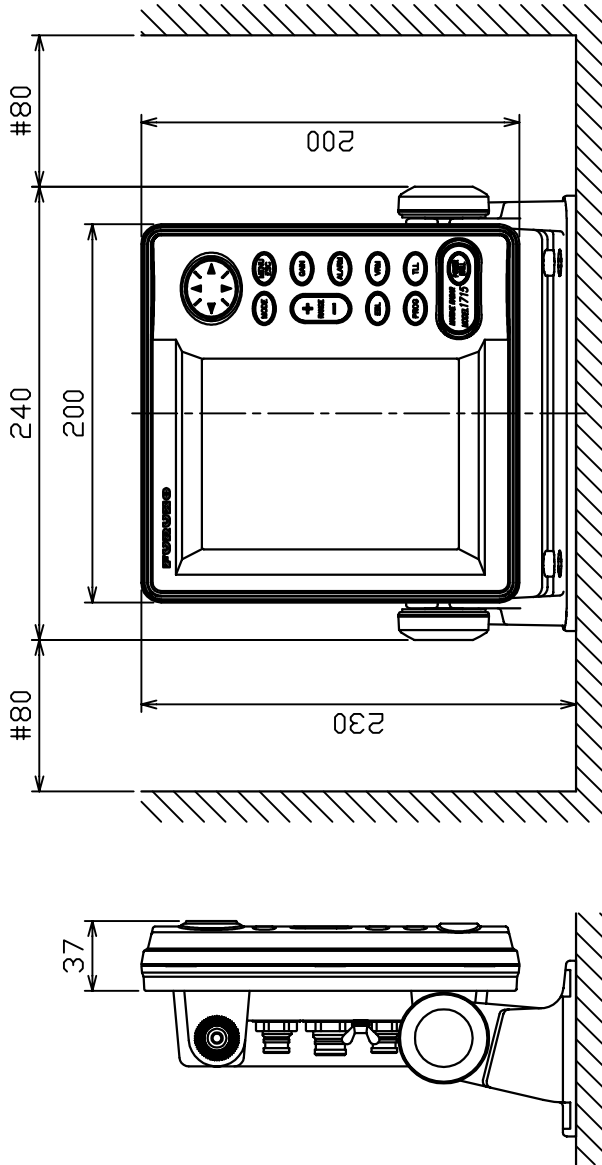
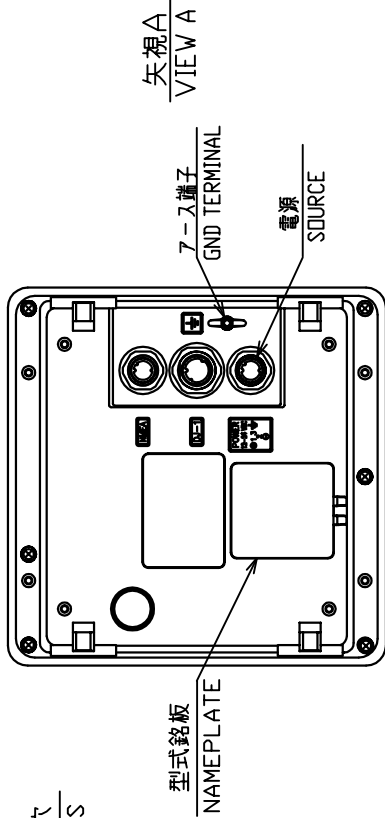
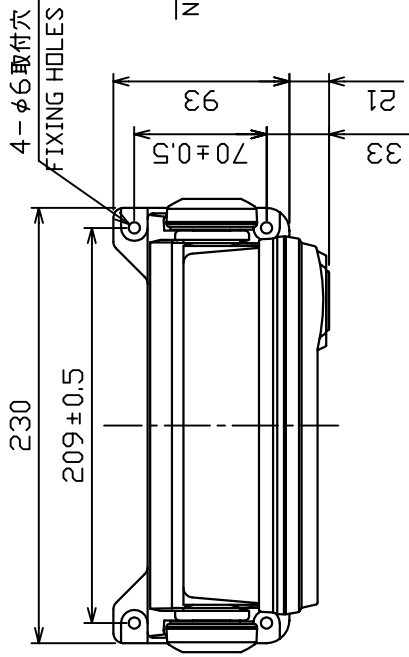

- 注記 1) #印寸法は最小サービスクリアランスとする。
 2) 指定外の寸法公差は表1による。
 3) 取付用ネジはトラスタップピンゲネジ呼び径5×20を使用のこと。
- NOTE 1. # INDICATES TOLERANCE OF DIMENSIONS WHICH IS NOT SPECIFIED.
 2. TABLE 1 INDICATES TOLERANCE OF DIMENSIONS WHICH IS NOT SPECIFIED.
 3. USE TAPPING SCREWS 5X20 FOR FIXING THE UNIT.

DRAWN 描	CHKD 検	APPROVED 認	SCALE 縮	DWG No. 図番	TITLE 名
Y. HATAI H. MAKI Takahashi T.			1/4	C3514-G01-A	RDP-142 指示部 (卓上装備)
					外寸図
					DISPLAY UNIT (TABLETOP MOUNT) OUTLINE DRAWING
					MODEL 1715 質量は付属カバーを含まず。 MASS W/O ACCESSORY COVER.
					03-165-100G

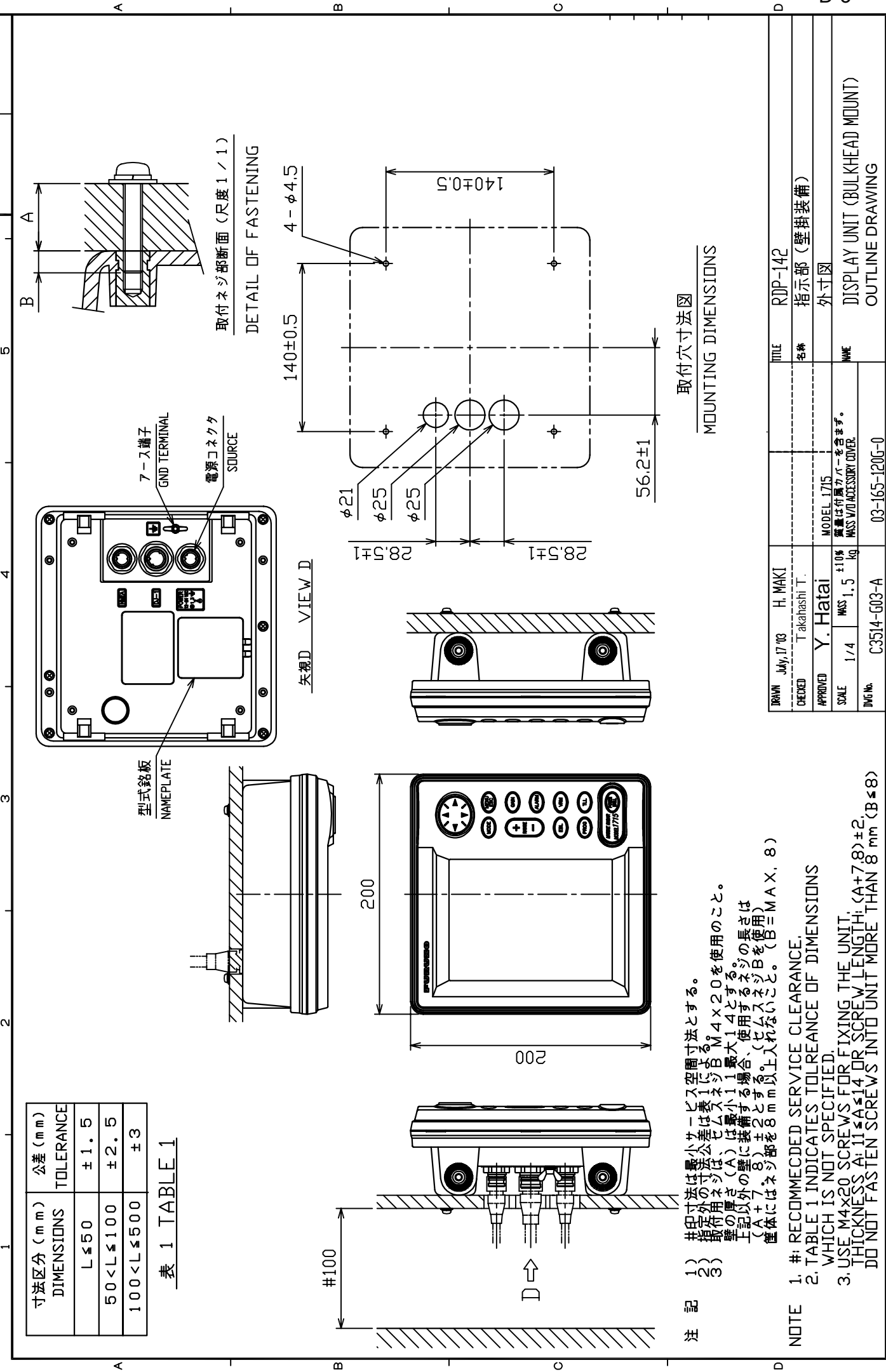

寸法区分 (mm)	公差 (mm)
DIMENSIONS	TOLERANCE
L ≤ 50	± 1.5
50 < L ≤ 100	± 2.5
100 < L ≤ 500	± 3

表 1 TABLE 1

取付穴寸法図

MOUNTING DIMENSIONS

- 注 記
- 1) #印寸法は最小カーブ半径とする。
 - 2) 指定外の寸法公差は表1による。M4×2.0を使用のこと。
 - 3) 取付用ネジは、壁の厚さ(A)は最小11の場合、使用するネジの長さは上記以外の壁に挿入する場合、(セムスネジBを使用) (A+7.8)より8mm以上入れないこと。(B≦MAX. 8) 筐体にはネジ部を8mm以上入れないこと。(B≦MAX. 8)
- NOTE
1. #: UNRECOMMENDED SERVICE CLEARANCE.
 2. TABLE 1 INDICATES TOLERANCE OF DIMENSIONS WHICH IS NOT SPECIFIED.
 3. USE M4x2.0 SCREWS FOR FIXING THE UNIT. THICKNESS A: IF A ≤ 14 OR SCREW LENGTH L: (A+7.8) ± 2. DO NOT FASTEN SCREWS INTO UNIT MORE THAN 8 mm (B ≤ 8)

DRAWN	DATE	DESIGNED	TITLE
JMY, 17'03	H. MAKI	RDP-142	名称
CHECKED	T. akahashi T.	指示部 (壁掛装備)	外寸図
APPROVED	Y. Hatai	MODEL 1715	DISPLAY UNIT (BULKHEAD MOUNT)
SCALE	1/4	質量は付属カバーを含まず。 MASS W/O ACCESSORY COVER.	OUTLINE DRAWING
FIG. No.	C3514-G03-A	03-165-1200-0	

1 2 3 4 5

寸法区分 (mm) DIMENSIONS	公差 (mm) TOLERANCE
L ≤ 50	± 1.5
50 < L ≤ 100	± 2.5
100 < L ≤ 500	± 3

表 1 TABLE 1

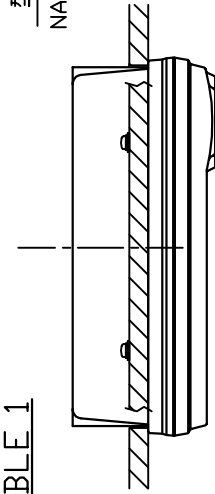

型式銘板
NAMEPLATE

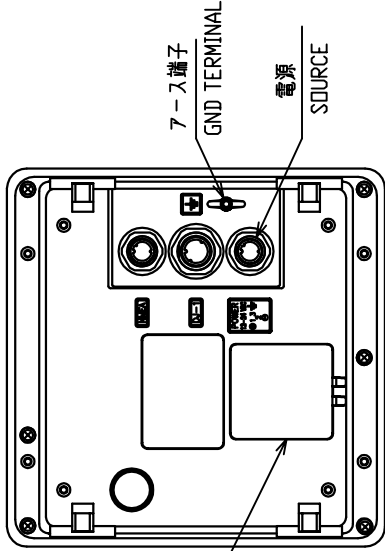

背面
REAR

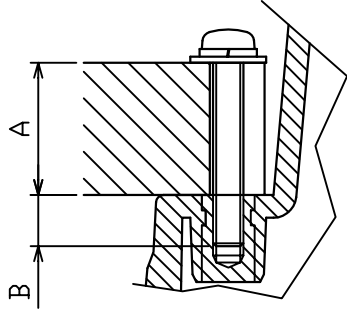

取付ネジ部断面 (尺度 1 / 1)
DETAIL OF FASTENING
(SCALE 1 / 1)

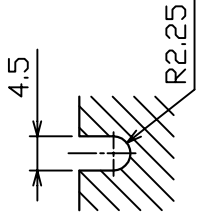

X部詳細 (尺度 1 / 1)
DETAIL X (SCALE 1 / 1)

A B C D

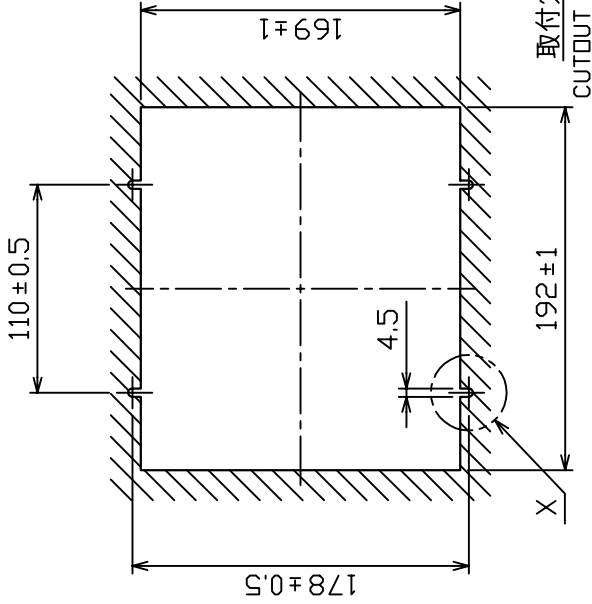
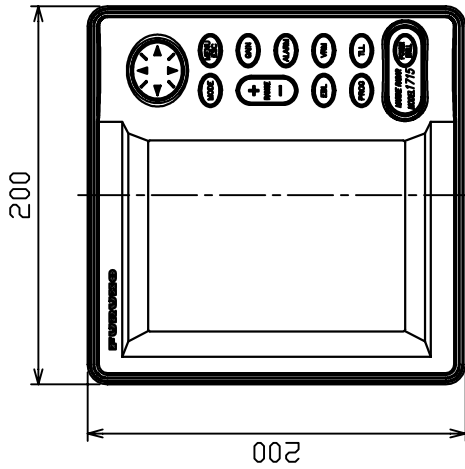
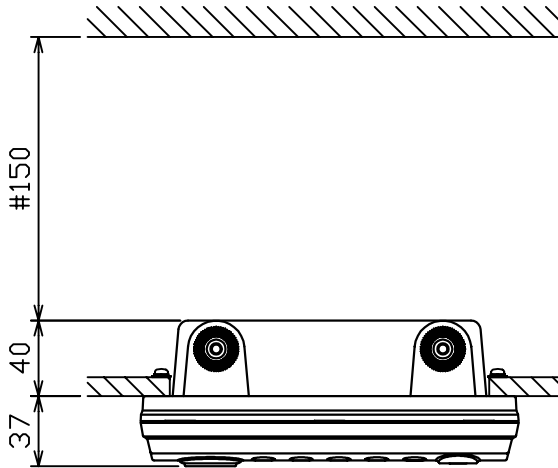

- 注 記
- 1) 寸法は最小サージ電圧を考慮して決定する。
 - 2) 取付穴の寸法は、M4×2.0を使用すること。
 - 3) 壁の厚さ(A)は、最小11mmとする。上記以外の壁に装着する場合は、使用するネジの長さ(A+7.8)とする。(セムスネジBを使用) 筐体にはネジ部を8mm以上入れないこと。(B ≤ MAX. 8)

取付穴寸法図
CUTOUT DIMENSIONS

DRAWN	DATE	DESIGNER	MODEL	TITLE
July 17 '03	H. MAKI	T. akahashi T.	MODEL 1715	RDP-142
CHECKED				名称 指示部 (埋込装備)
APPROVED	Y. Hatai			外寸図
SCALE	1/4	WGT 1.3 ±10% KG		質量は付属カバーを含まず。 MASS W/O ACCESSORY COVER.
DWG No.	C3514-G02-A			DISPLAY UNIT (FLUSHMOUNT) OUTLINE DRAWING
				03-165-110G

NOTE

1. #1 INDICATES SERVICE CLEARANCE.
2. TABLE 1 INDICATES TOLERANCE OF DIMENSIONS WHICH IS NOT SPECIFIED.
3. USE M4x2.0 SCREWS FOR FIXING THE UNIT. THICKNESS A-11 ≤ A ≤ 14 OR SCREW LENGTH L1 (A+7.8) ± 2. DO NOT FASTEN SCREWS INTO UNIT MORE THAN 8 mm (B ≤ 8)

4

3

2

1

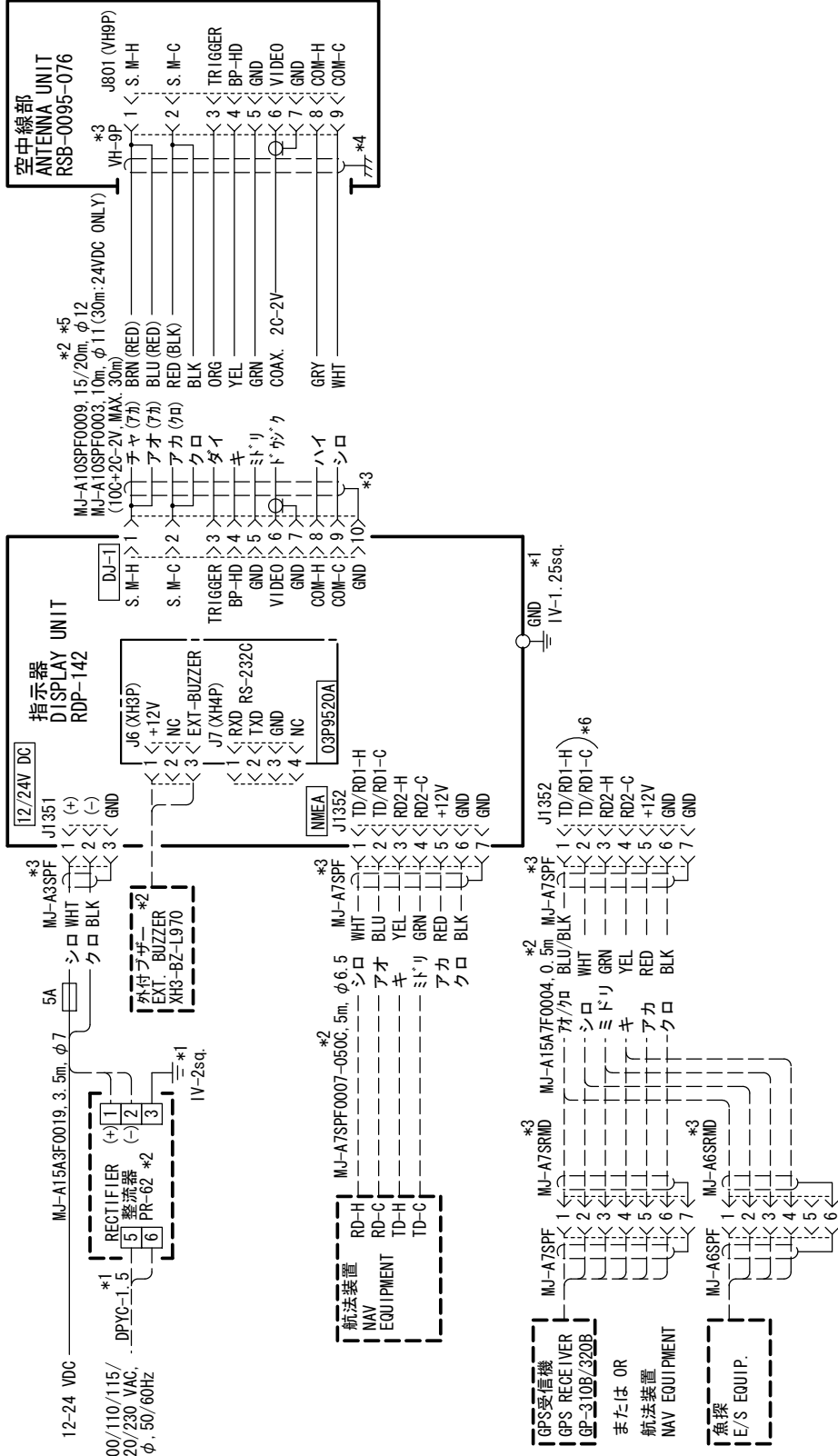

注記

- *1) 造船所手配。
- *2) オプション。
- *3) 工場にて取付済み。
- *4) 空中線部のシールドは完全にアースする。
- *5) () : MJ-A10SPF0009の芯線色を示す。
- *6) MJ-A15A7F0004使用時は、メニューでRDを選択。

NOTE

- *1: SHIPYARD SUPPLY.
- *2: OPTION.
- *3: FITTED AT FACTORY.
- *4: GROUND EFFECTIVELY AT SCANNER UNIT.
- *5: () : WIRE COLOR OF MJ-A10SPF0009.
- *6: SELECT RD FROM MENU WHEN MJ-A15A7F0004 CABLE IS USED.

DRAWN	15/Feb/2011	T. YAMASAKI	TITLE	MODEL 1715
CHECKED	15/Feb/2011	H. MAKI	名称	船舶用レーダー
APPROVED	16/Feb/2011	Y. NISHIYAMA		相互結線図
SCALE	MASS	kg	NAME	MARINE RADAR
DRWG. No.	C3514-001-D		REF. No.	03-165-6001-0
				INTERCONNECTION DIAGRAM

FURUNO Worldwide Warranty for Pleasure Boats (Except North America)

This warranty is valid for products manufactured by Furuno Electric Co. (hereafter FURUNO) and installed on a pleasure boat. Any web based purchases that are imported into other countries by anyone other than a FURUNO certified dealer may not comply with local standards. FURUNO strongly recommends against importing these products from international websites as the imported product may not work correctly and may interfere with other electronic devices. The imported product may also be in breach of the local laws and mandated technical requirements. Products imported into other countries as described previously shall not be eligible for local warranty service.

For products purchased outside of your country please contact the national distributor of Furuno products in the country where purchased.

This warranty is in addition to the customer's statutory legal rights.

1. Terms and Conditions of Warranty

FURUNO guarantees that each new FURUNO product is the result of quality materials and workmanship. The warranty is valid for a period of 2 years (24 months) from the date of the invoice, or the date of commissioning of the product by the installing certified dealer.

2. FURUNO Standard Warranty

The FURUNO standard warranty covers spare parts and labour costs associated with a warranty claim, provided that the product is returned to a FURUNO national distributor by prepaid carrier.

The FURUNO standard warranty includes:

- Repair at a FURUNO national distributor
- All spare parts for the repair
- Cost for economical shipment to customer

3. FURUNO Onboard Warranty

If the product was installed/commissioned and registered by a certified FURUNO dealer, the customer has the right to the onboard warranty.

The FURUNO onboard warranty includes

- Free shipping of the necessary parts
- Labour: Normal working hours only
- Travel time: Up to a maximum of two (2) hours
- Travel distance: Up to a maximum of one hundred and sixty (160) KM by car for the complete journey

4. Warranty Registration

For the Standard Warranty - presentation of product with serial number (8 digits serial number, 1234-5678) is sufficient. Otherwise, the invoice with serial number, name and stamp of the dealer and date of purchase is shown.

For the Onboard Warranty your FURUNO certified dealer will take care of all registrations.

5. Warranty Claims

For the Standard Warranty - simply send the defective product together with the invoice to a FURUNO national distributor. For the Onboard Warranty – contact a FURUNO national distributor or a certified dealer. Give the product's serial number and describe the problem as accurately as possible.

Warranty repairs carried out by companies/persons other than a FURUNO national distributor or a certified dealer is not covered by this warranty.

6. Warranty Limitations

When a claim is made, FURUNO has a right to choose whether to repair the product or replace it.

The FURUNO warranty is only valid if the product was correctly installed and used. Therefore, it is necessary for the customer to comply with the instructions in the handbook. Problems which result from not complying with the instruction manual are not covered by the warranty.

FURUNO is not liable for any damage caused to the vessel by using a FURUNO product.

The following are excluded from this warranty:

- a. Second-hand product
- b. Underwater unit such as transducer and hull unit
- c. Routine maintenance, alignment and calibration services.
- d. Replacement of consumable parts such as fuses, lamps, recording papers, drive belts, cables, protective covers and batteries.
- e. Magnetron and MIC with more than 1000 transmitting hours or older than 12 months, whichever comes first.
- f. Costs associated with the replacement of a transducer (e.g. Crane, docking or diver etc.).
- g. Sea trial, test and evaluation or other demonstrations.
- h. Products repaired or altered by anyone other than the FURUNO national distributor or an authorized dealer.
- i. Products on which the serial number is altered, defaced or removed.
- j. Problems resulting from an accident, negligence, misuse, improper installation, vandalism or water penetration.
- k. Damage resulting from a force majeure or other natural catastrophe or calamity.
- l. Damage from shipping or transit.
- m. Software updates, except when deemed necessary and warrantable by FURUNO.
- n. Overtime, extra labour outside of normal hours such as weekend/holiday, and travel costs above the 160 KM allowance
- o. Operator familiarization and orientation.

FURUNO Electric Company, March 1, 2011

FURUNO Warranty for North America

FURUNO U.S.A., Limited Warranty provides a twenty-four (24) months LABOR and twenty-four (24) months PARTS warranty on products from the date of installation or purchase by the original owner. Products or components that are represented as being waterproof are guaranteed to be waterproof only for, and within the limits, of the warranty period stated above. The warranty start date may not exceed eighteen (18) months from the original date of purchase by dealer from Furuno USA and applies to new equipment installed and operated in accordance with Furuno USA's published instructions.

Magnetrons and Microwave devices will be warranted for a period of 12 months from date of original equipment installation.

Furuno U.S.A., Inc. warrants each new product to be of sound material and workmanship and through its authorized dealer will exchange any parts proven to be defective in material or workmanship under normal use at no charge for a period of 24 months from the date of installation or purchase.

Furuno U.S.A., Inc., through an authorized Furuno dealer will provide labor at no cost to replace defective parts, exclusive of routine maintenance or normal adjustments, for a period of 24 months from installation date provided the work is done by Furuno U.S.A., Inc. or an AUTHORIZED Furuno dealer during normal shop hours and within a radius of 50 miles of the shop location.

A suitable proof of purchase showing date of purchase, or installation certification must be available to Furuno U.S.A., Inc., or its authorized dealer at the time of request for warranty service.

This warranty is valid for installation of products manufactured by Furuno Electric Co. (hereafter FURUNO). Any purchases from brick and mortar or web-based resellers that are imported into other countries by anyone other than a FURUNO certified dealer, agent or subsidiary may not comply with local standards. FURUNO strongly recommends against importing these products from international websites or other resellers, as the imported product may not work correctly and may interfere with other electronic devices. The imported product may also be in breach of the local laws and mandated technical requirements. Products imported into other countries, as described previously, shall not be eligible for local warranty service.

For products purchased outside of your country please contact the national distributor of Furuno products in the country where purchased.

WARRANTY REGISTRATION AND INFORMATION

To register your product for warranty, as well as see the complete warranty guidelines and limitations, please visit www.furunousa.com and click on "Support". In order to expedite repairs, warranty service on Furuno equipment is provided through its authorized dealer network. If this is not possible or practical, please contact Furuno U.S.A., Inc. to arrange warranty service.

FURUNO U.S.A., INC.
Attention: Service Coordinator
4400 N.W. Pacific Rim Boulevard
Camas, WA 98607-9408
Telephone: (360) 834-9300
FAX: (360) 834-9400

Furuno U.S.A., Inc. is proud to supply you with the highest quality in Marine Electronics. We know you had several choices when making your selection of equipment, and from everyone at Furuno we thank you. Furuno takes great pride in customer service.

Declaration of Conformity

[MODEL 1715]

- Bulgarian (BG)** С настоящото Furuno Electric Co., Ltd. декларира, че гореспоменат тип радиосъоръжение е в съответствие с Директива 2014/53/ЕС.
Цялостният текст на ЕС декларацията за съответствие може да се намери на следния интернет адрес:
- Spanish (ES)** Por la presente, Furuno Electric Co., Ltd. declara que el tipo de equipo radioeléctrico arriba mencionado es conforme con la Directiva 2014/53/UE.
El texto completo de la declaración UE de conformidad está disponible en la dirección Internet siguiente:
- Czech (CS)** Tímto Furuno Electric Co., Ltd. prohlašuje, že výše zmíněné typ rádiového zařízení je v souladu se směrnicí 2014/53/EU.
Úplné znění EU prohlášení o shodě je k dispozici na této internetové adrese:
- Danish (DA)** Hermed erklærer Furuno Electric Co., Ltd., at ovennævnte radioudstyr er i overensstemmelse med direktiv 2014/53/EU.
EU-overensstemmelseserklæringens fulde tekst kan findes på følgende internetadresse:
- German (DE)** Hiermit erkläre die Furuno Electric Co., Ltd., dass der oben genannte Funkanlagentyp der Richtlinie 2014/53/EU entspricht.
Der vollständige Text der EU-Konformitätserklärung ist unter der folgenden Internetadresse verfügbar:
- Estonian (ET)** Käesolevaga deklareerib Furuno Electric Co., Ltd., et ülalmainitud raadioseadme tüüp vastab direktiivi 2014/53/EL nõuetele.
ELi vastavusdeklaratsiooni täielik tekst on kättesaadav järgmisel internetiaadressil:
- Greek (EL)** Με την παρούσα η Furuno Electric Co., Ltd., δηλώνει ότι ο προαναφερθέντας ραδιοεξοπλισμός πληροί την οδηγία 2014/53/ΕΕ.
Το πλήρες κείμενο της δήλωσης συμμόρφωσης ΕΕ διατίθεται στην ακόλουθη ιστοσελίδα στο διαδίκτυο:
- English (EN)** Hereby, Furuno Electric Co., Ltd. declares that the above-mentioned radio equipment type is in compliance with Directive 2014/53/EU.
The full text of the EU declaration of conformity is available at the following internet address:
- French (FR)** Le soussigné, Furuno Electric Co., Ltd., déclare que l'équipement radioélectrique du type mentionné ci-dessus est conforme à la directive 2014/53/UE.
Le texte complet de la déclaration UE de conformité est disponible à l'adresse internet suivante:
- Croatian (HR)** Furuno Electric Co., Ltd. ovime izjavljuje da je gore rečeno radijska oprema tipa u skladu s Direktivom 2014/53/EU.
Cjeloviti tekst EU izjave o sukladnosti dostupan je na sljedećoj internetskoj adresi:
- Italian (IT)** Il fabbricante, Furuno Electric Co., Ltd., dichiara che il tipo di apparecchiatura radio menzionato sopra è conforme alla direttiva 2014/53/UE.
Il testo completo della dichiarazione di conformità UE è disponibile al seguente indirizzo Internet:
- Latvian (LV)** Ar šo Furuno Electric Co., Ltd. deklarē, ka augstāk minēts radioiekārta atbilst Direktīvai 2014/53/ES.
Pilns ES atbilstības deklarācijas teksts ir pieejams šādā interneta vietnē:

Lithuanian (LT)	Aš, Furuno Electric Co., Ltd., patvirtinu, kad pirmiau minėta radijo įrenginių tipas atitinka Direktyvą 2014/53/ES. Visas ES atitikties deklaracijos tekstas prieinamas šiuo interneto adresu:
Hungarian (HU)	Furuno Electric Co., Ltd. igazolja, hogy fent említett típusú rádióberendezés megfelel a 2014/53/EU irányelvnek. Az EU-megfelelőségi nyilatkozat teljes szövege elérhető a következő internetes címen:
Maltese (MT)	B'dan, Furuno Electric Co., Ltd., niddikjara li msemmija hawn fuq-tip ta' tagħmir tar-radju huwa konformi mad-Direttiva 2014/53/UE. It-test kollu tad-dikjarazzjoni ta' konformità tal-UE huwa disponibbli f'dan l-indirizz tal-Internet li ġej:
Dutch (NL)	Hierbij verklaar ik, Furuno Electric Co., Ltd., dat het hierboven genoemde type radioapparaat conform is met Richtlijn 2014/53/EU. De volledige tekst van de EU-conformiteitsverklaring kan worden geraadpleegd op het volgende internetadres:
Polish (PL)	Furuno Electric Co., Ltd. niniejszym oświadczam, że wyżej wymieniony typ urządzenia radiowego jest zgodny z dyrektywą 2014/53/UE. Pełny tekst deklaracji zgodności UE jest dostępny pod następującym adresem internetowym:
Portuguese (PT)	O(a) abaixo assinado(a) Furuno Electric Co., Ltd. declara que o mencionado acima tipo de equipamento de rádio está em conformidade com a Diretiva 2014/53/UE. O texto integral da declaração de conformidade está disponível no seguinte endereço de Internet:
Romanian (RO)	Prin prezenta, Furuno Electric Co., Ltd. declară că menționat mai sus tipul de echipamente radio este în conformitate cu Directiva 2014/53/UE. Textul integral al declarației UE de conformitate este disponibil la următoarea adresă internet:
Slovak (SK)	Furuno Electric Co., Ltd. týmto vyhlasuje, že vyššie spomínané rádiové zariadenie typu je v súlade so smernicou 2014/53/EÚ. Úplné EÚ vyhlásenie o zhode je k dispozícii na tejto internetovej adrese:
Slovenian (SL)	Furuno Electric Co., Ltd. potrjuje, da je zgoraj omenjeno tip radijske opreme skladen z Direktivo 2014/53/EU. Celotno besedilo izjave EU o skladnosti je na voljo na naslednjem spletnem naslovu:
Finnish (FI)	Furuno Electric Co., Ltd. vakuuttaa, että yllä mainittu radiolaitetyyppi on direktiivin 2014/53/EU mukainen. EU-vaatimusten mukaisuusvakuutuksen täysimittainen teksti on saatavilla seuraavassa internetosoitteessa:
Swedish (SV)	Härmed försäkrar Furuno Electric Co., Ltd. att ovan nämnda typ av radioutrustning överensstämmer med direktiv 2014/53/EU. Den fullständiga texten till EU-försäkran om överensstämmelse finns på följande webbadress:

Online Resource

http://www.furuno.com/en/support/red_doc

ECF

(Elemental Chlorine Free)

The paper used in this manual
is elemental chlorine free.

FURUNO ELECTRIC CO., LTD.

9-52 Ashihara-cho,
Nishinomiya, 662-8580, JAPAN

• FURUNO Authorized Distributor/Dealer

All rights reserved. Printed in Japan

Pub. No. OME-35140-D2

(ETMI) MODEL1715

A : AUG. 2003

D2 : FEB. 22, 2017



0 0 0 1 4 7 9 0 9 1 3